

Flat bench press with leg developer plan

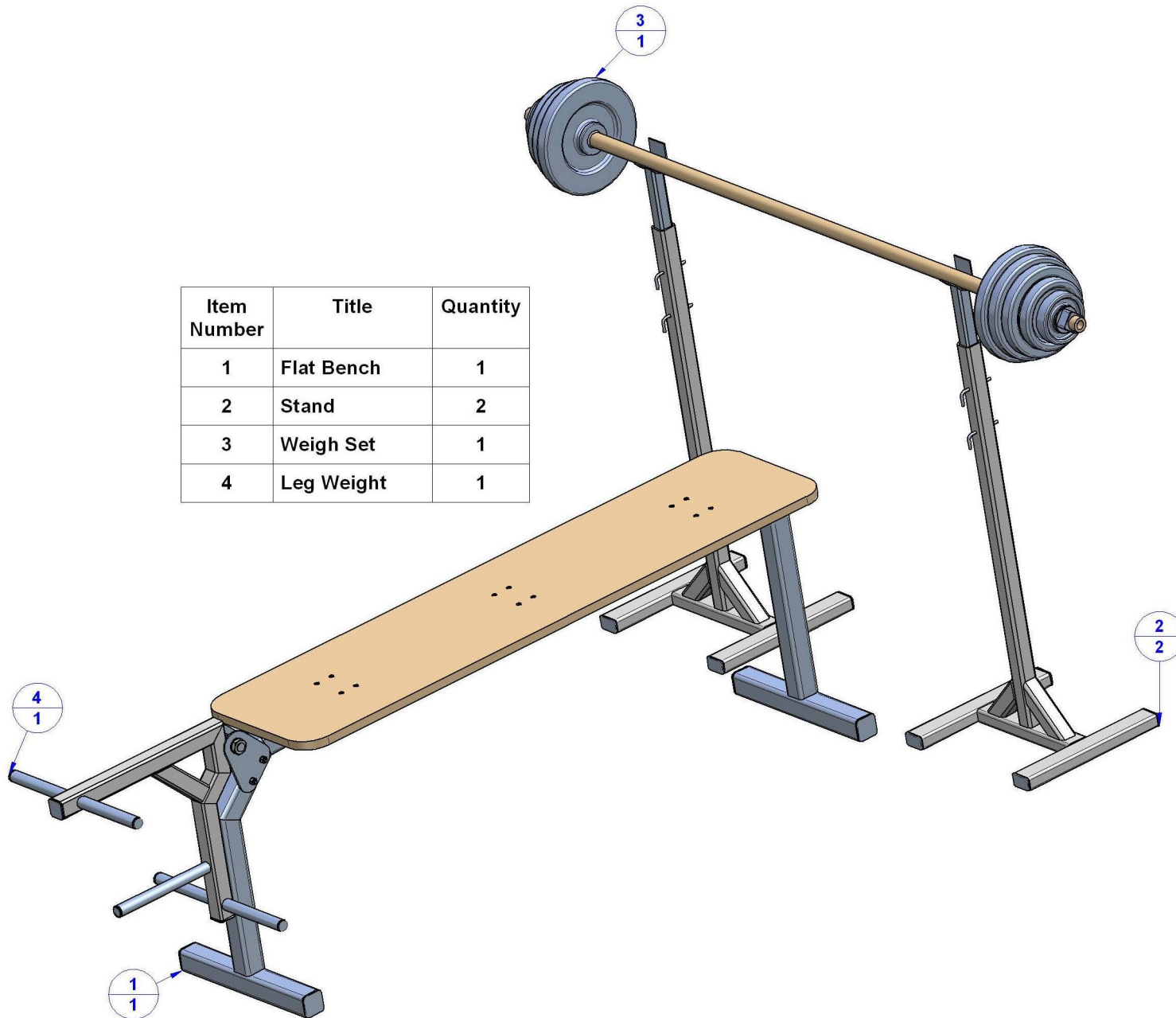

Sub-assembly list

Item Number	Title	Quantity
1	Flat Bench	1
2	Stand	2
3	Weigh Set	1
4	Leg Weight	1



1. Flat bench sub-assembly – Parts list and 2D documentation

Item Number	Title	Material	Quantity	Category	Cut Length
1	SQUARE TUBING 50x50x4	Steel	1		365.36 mm
2	SQUARE TUBING 50x50x4	Steel	1		190.42 mm
3	SQUARE TUBING 50x50x4	Steel	1		1435.36 mm
4	SQUARE TUBING 50x50x4	Steel	1		500.00 mm
5	SQUARE TUBING 50x50x4	Steel	2		400.00 mm
6	Sheet	wood	1		
7	Sheet Support	Steel	6		
8	Triangle support	Steel	6		
9	Slotted pan head screw M5x30	Steel	12	Standard Part	
10	Spring lock washer	Steel	12	Standard Part	
11	Hexagon nut M5	Steel	12	Standard Part	
12	Cover 50x50mm	Steel	4		

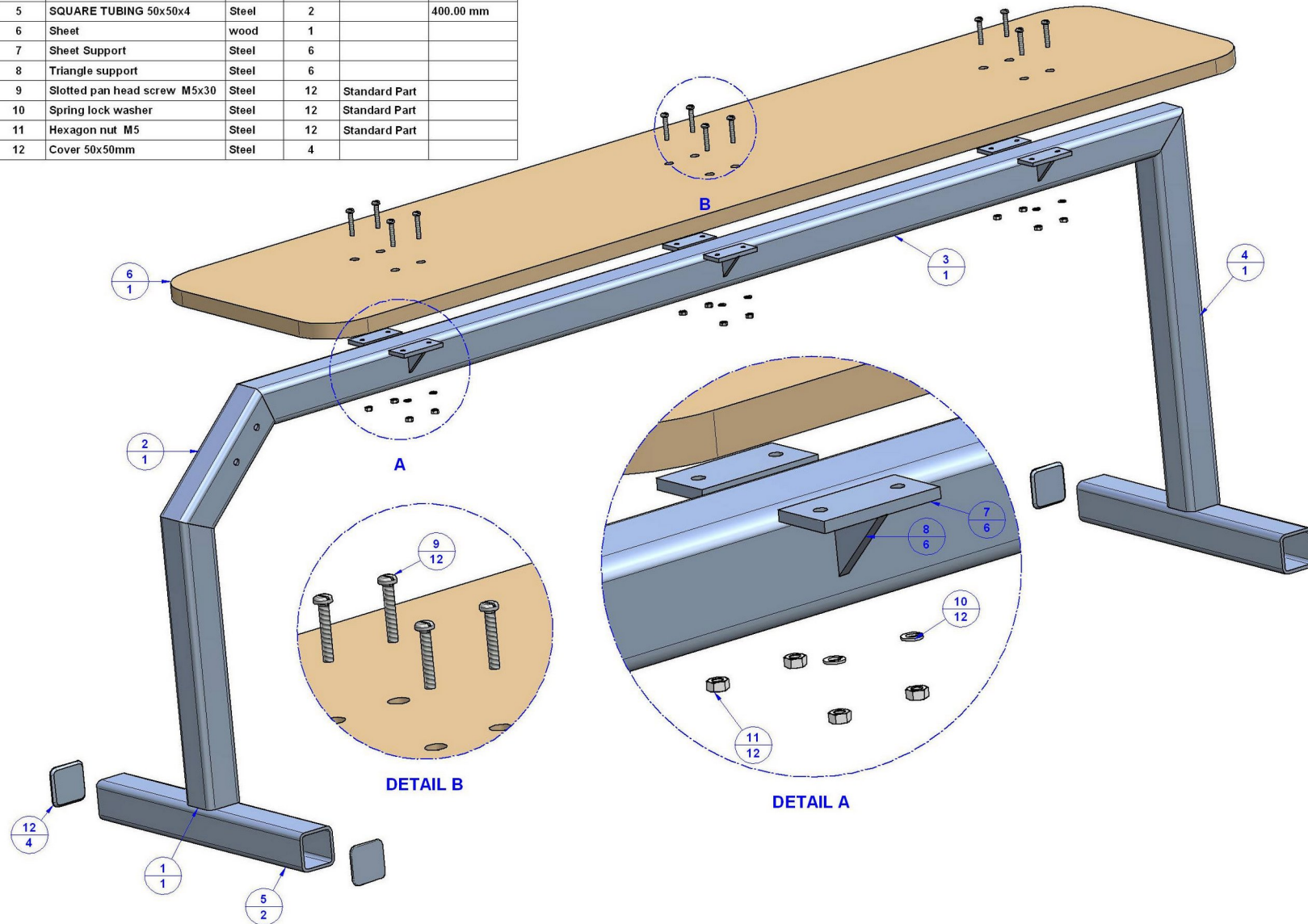

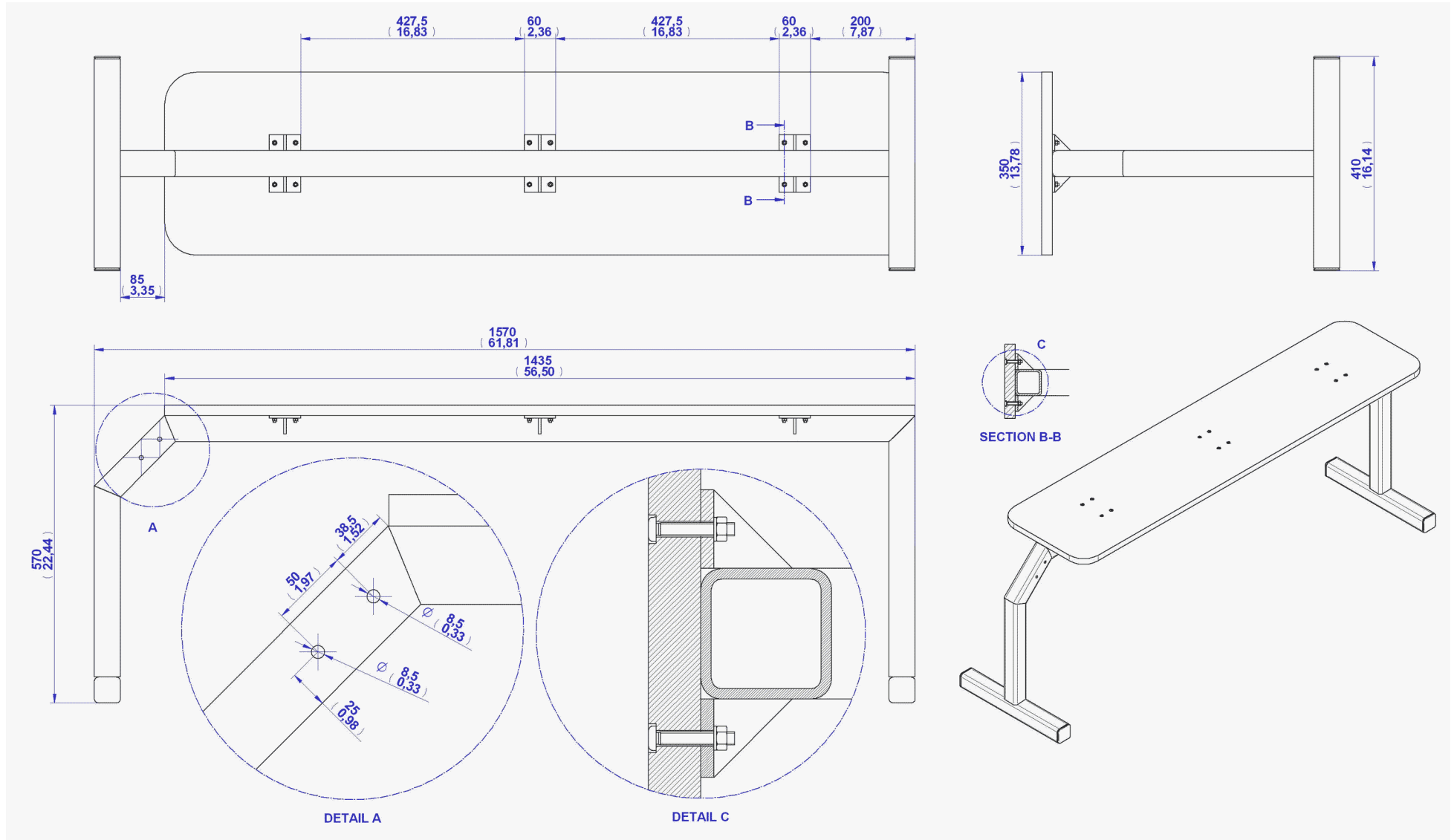

Frame components

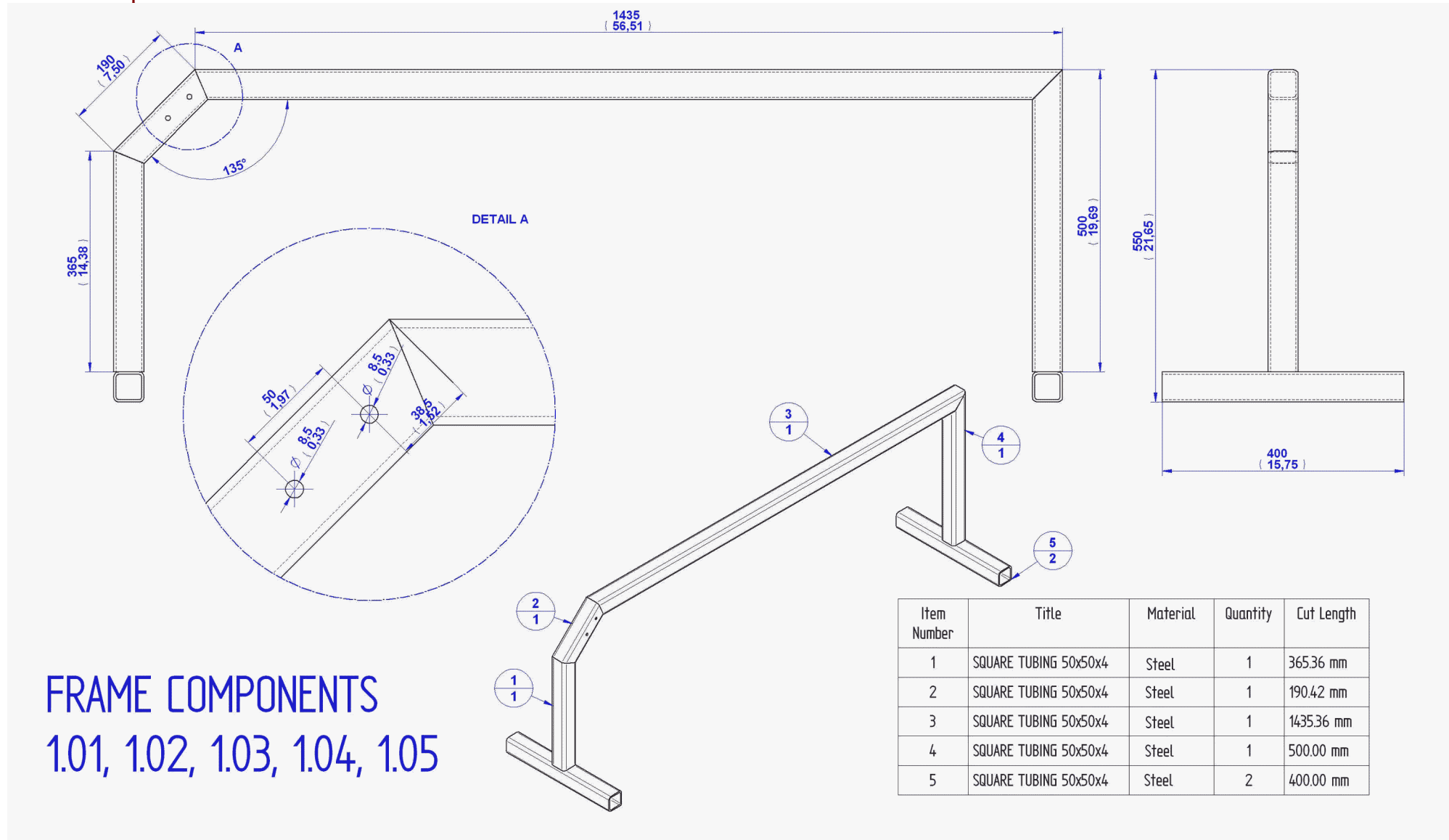

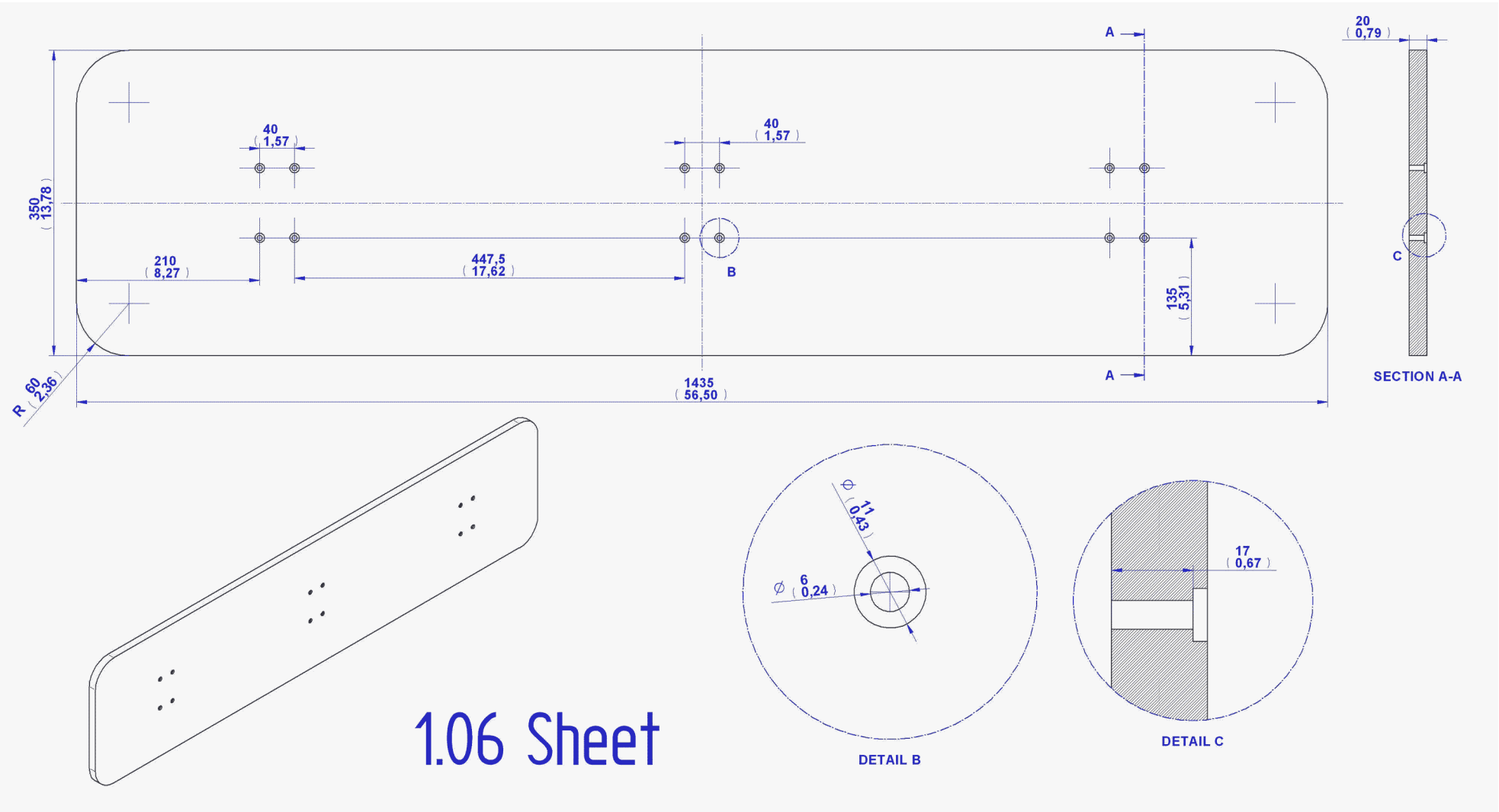

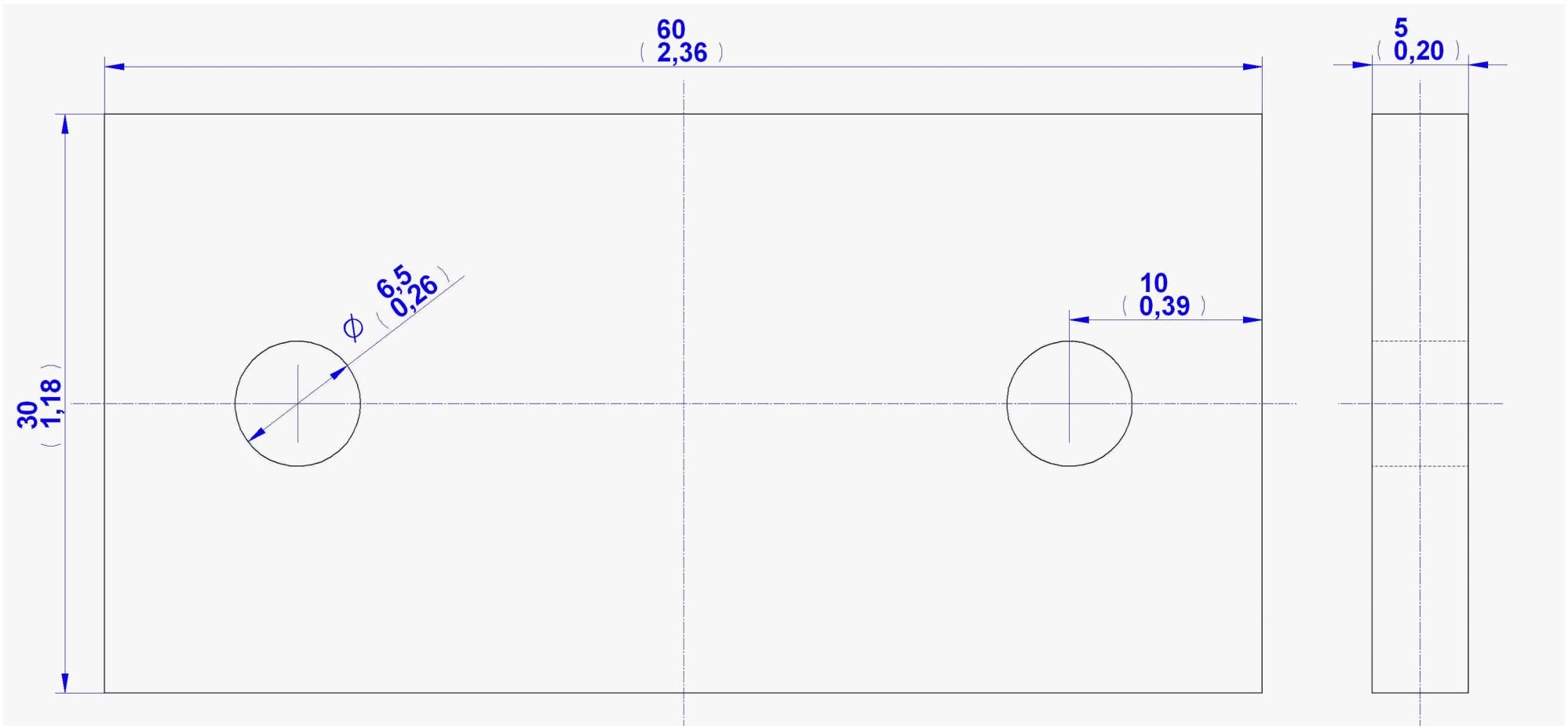

1.07 Sheet Support

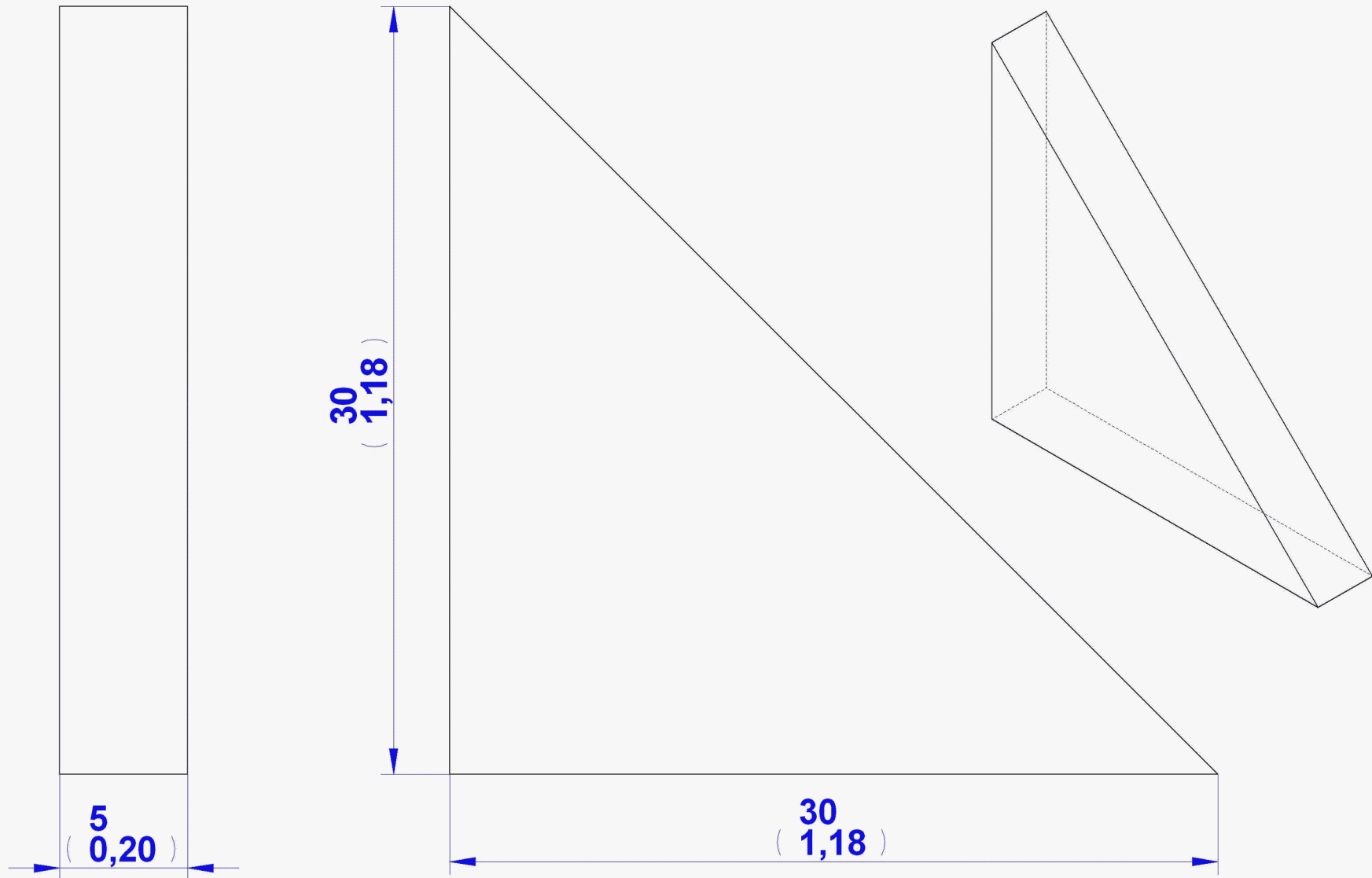

1.08 Triangle Support

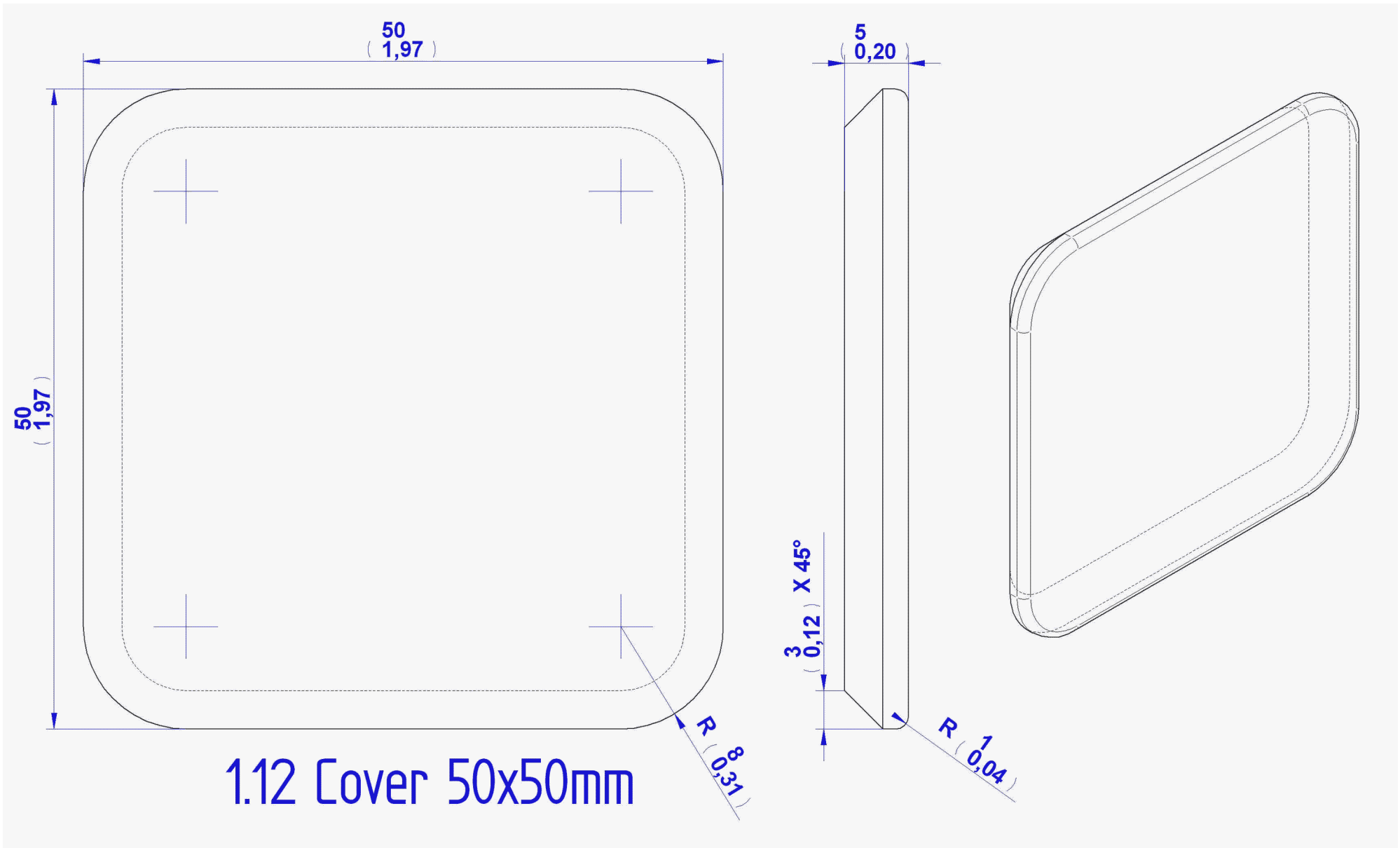

Standard Parts

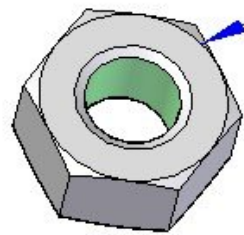

1.11 Hexagon Nut M10

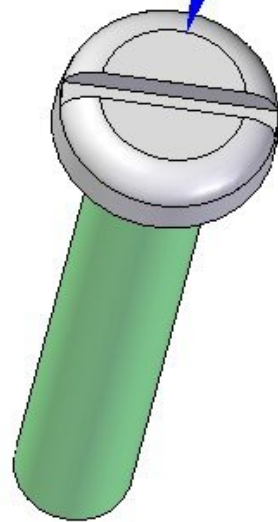

1.09 Slotted Pan Head Screw M5 x 30mm

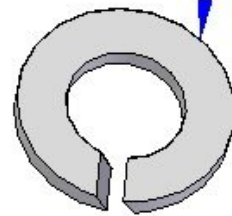

1.10 Spring Lock Washer 5

Standard Parts

2. Stand sub-assembly – Parts list and 2D documentation

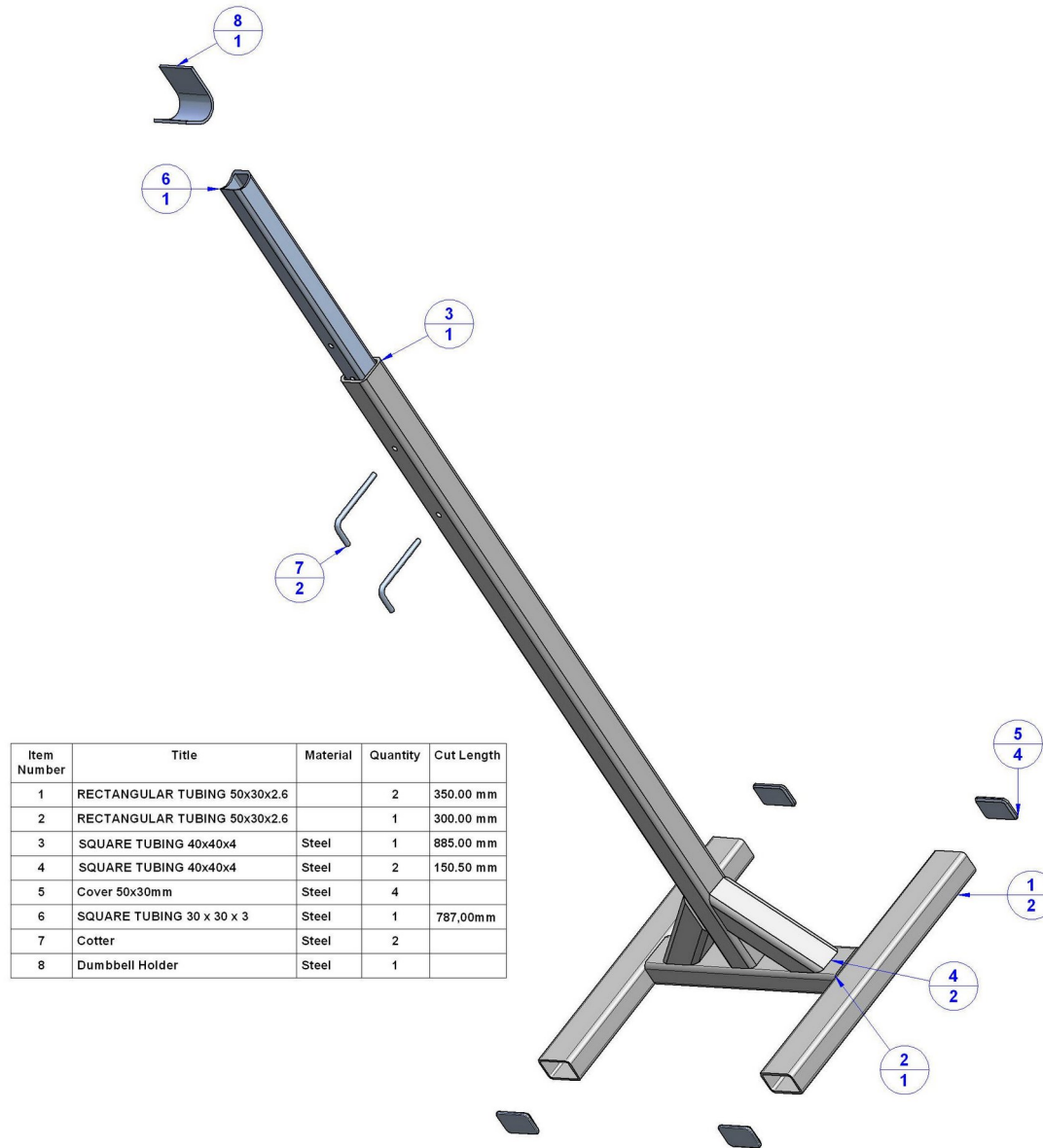

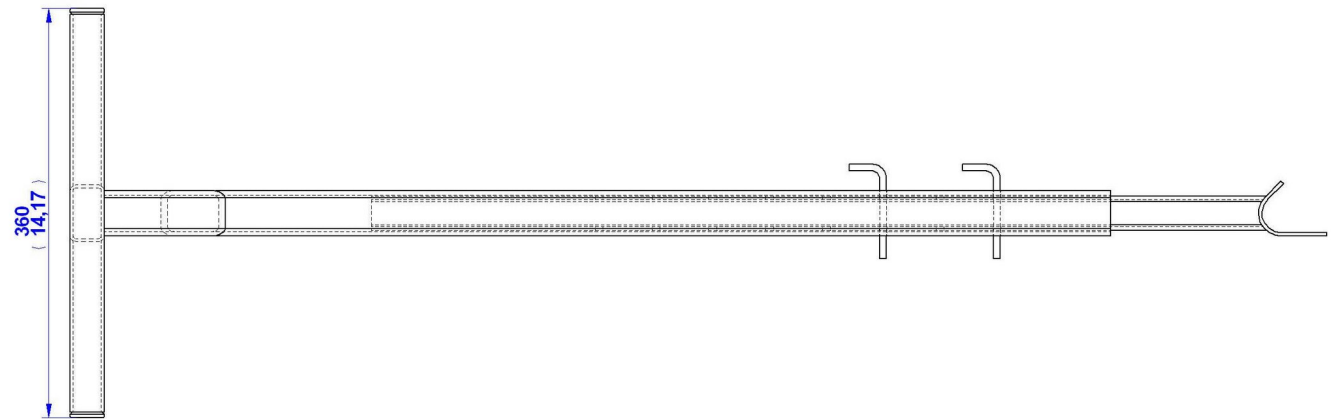
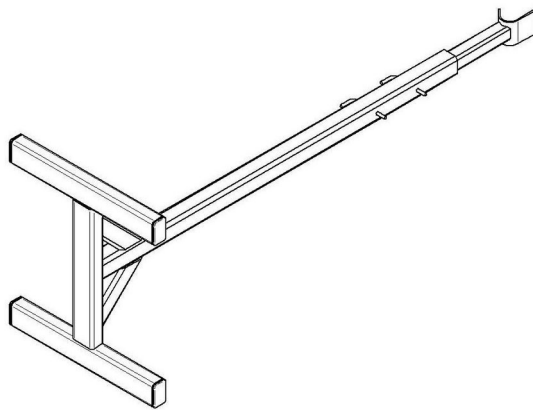
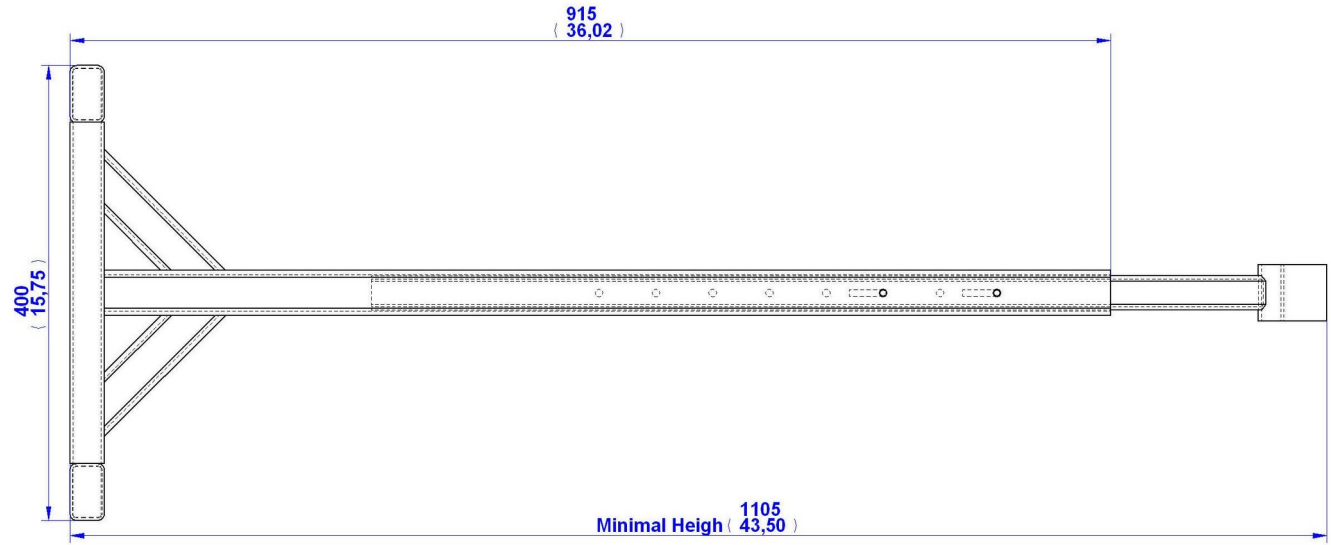
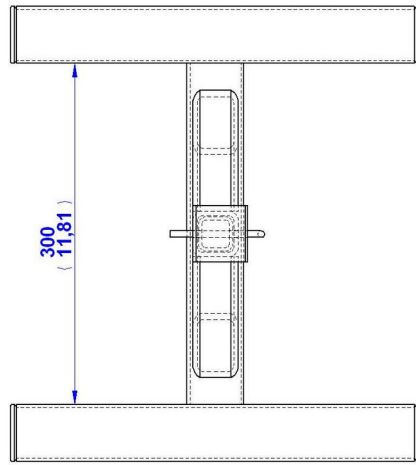

Frame components

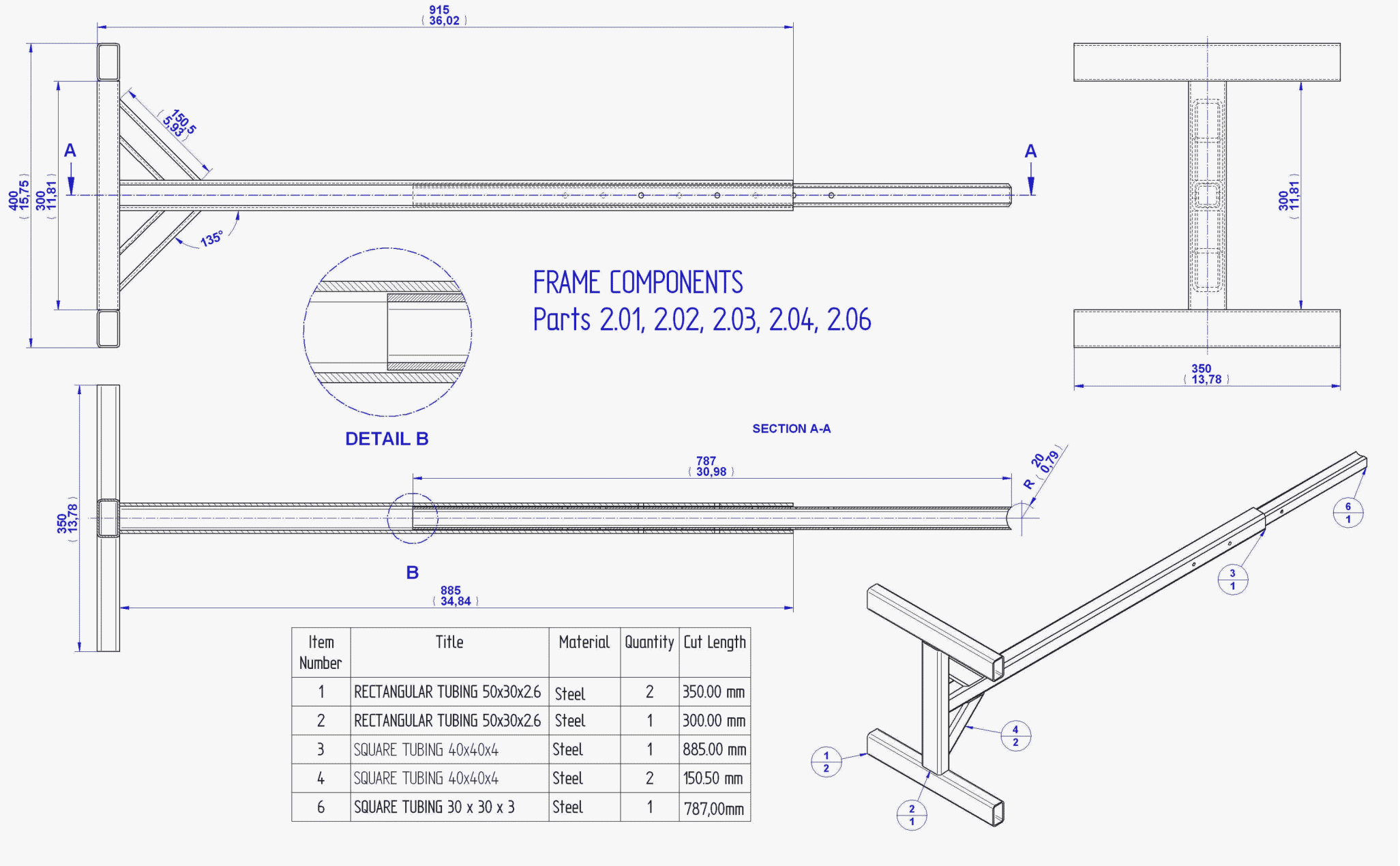

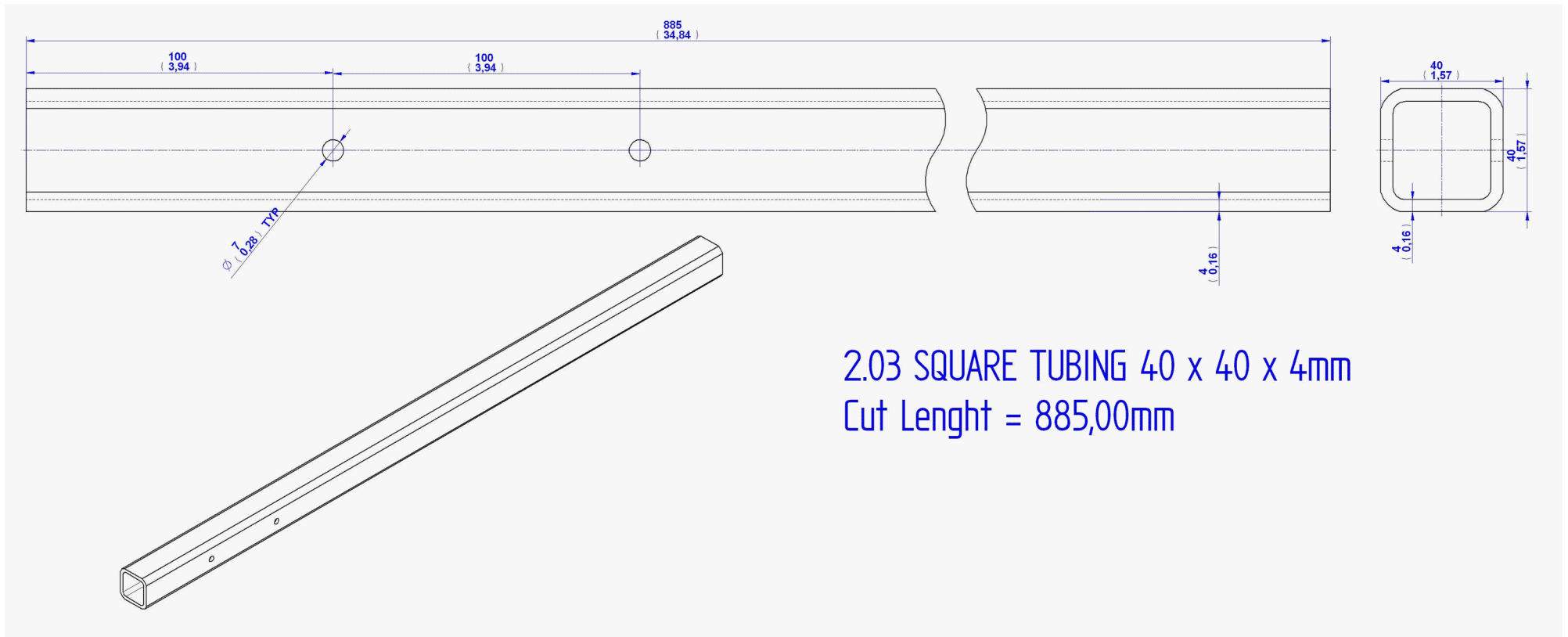

2.03 SQUARE TUBING 40 x 40 x 4mm
Cut Length = 885,00mm

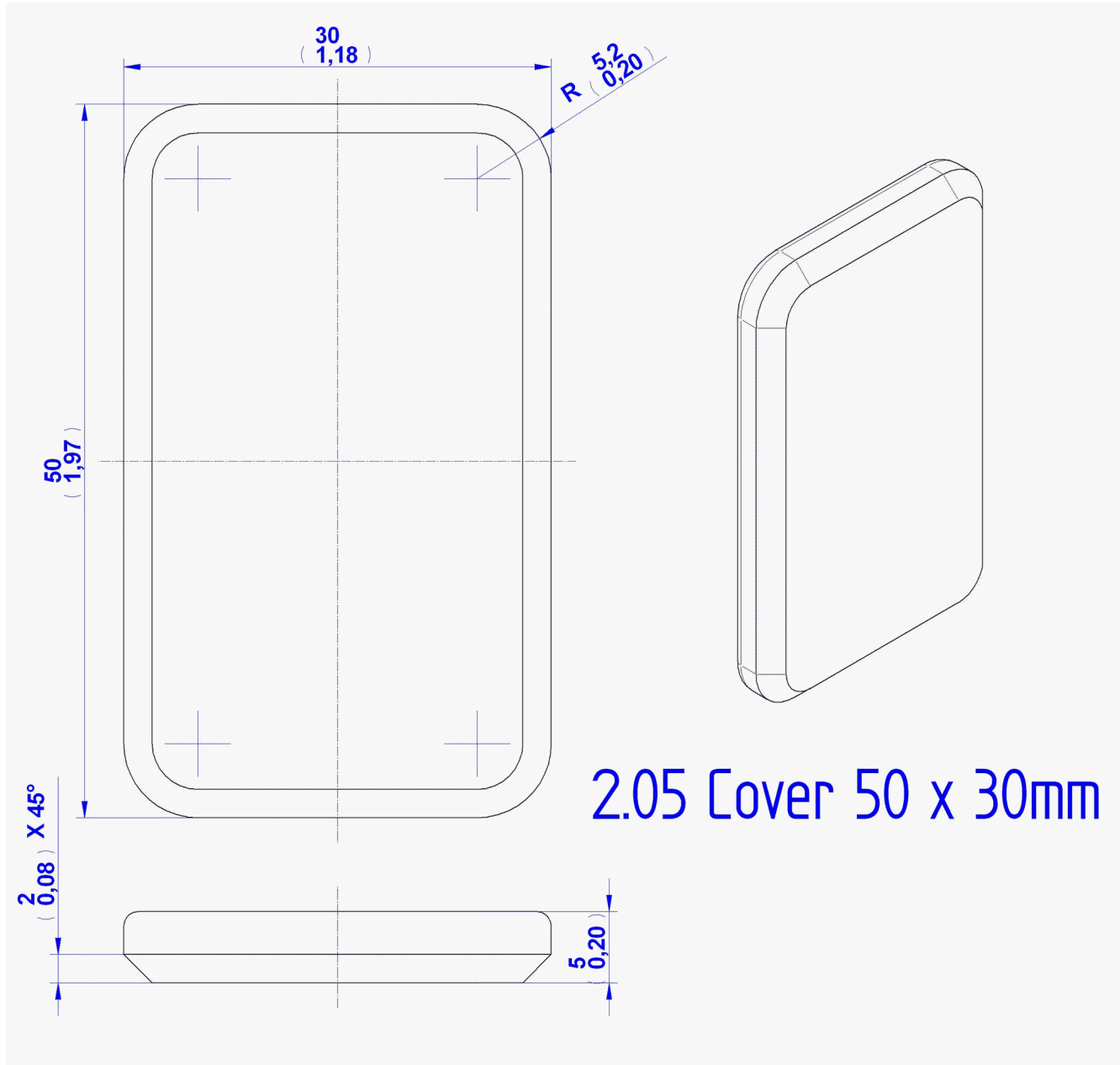

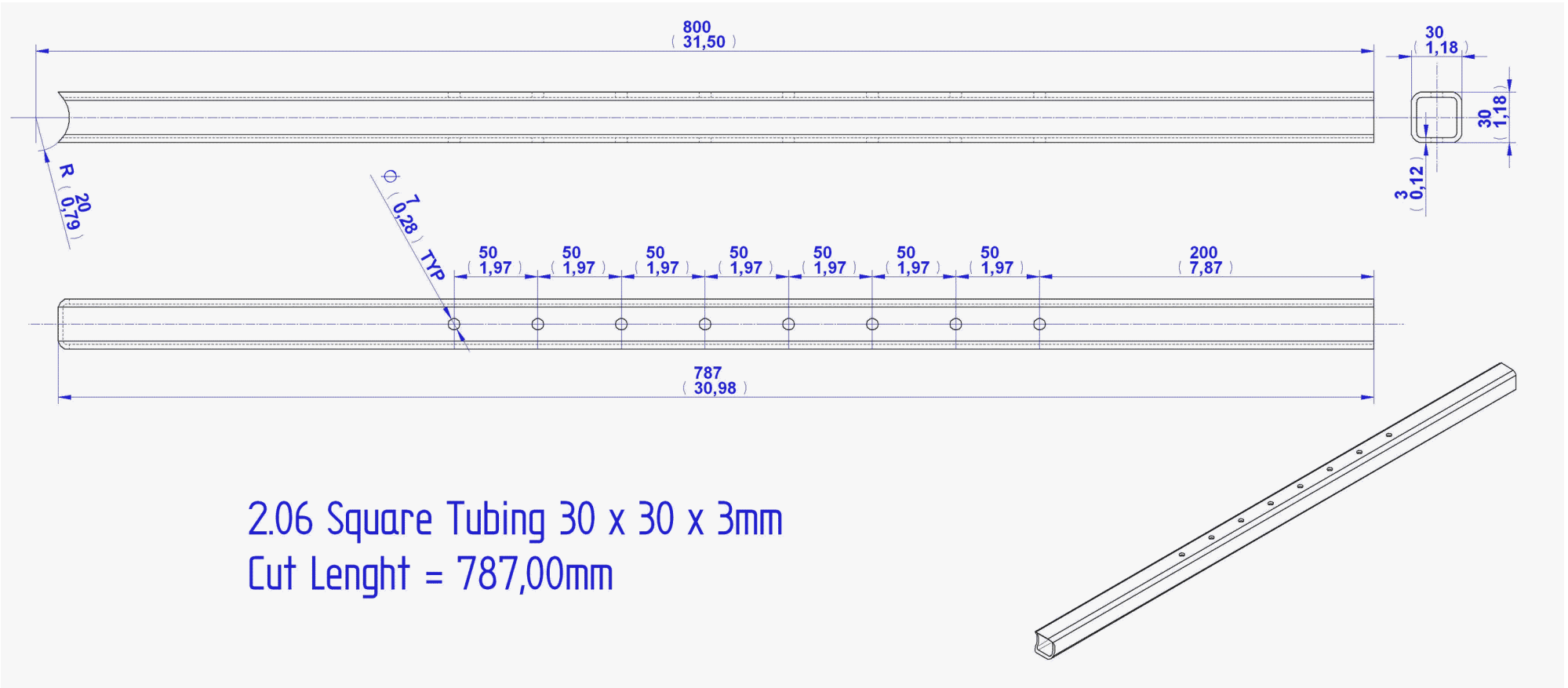

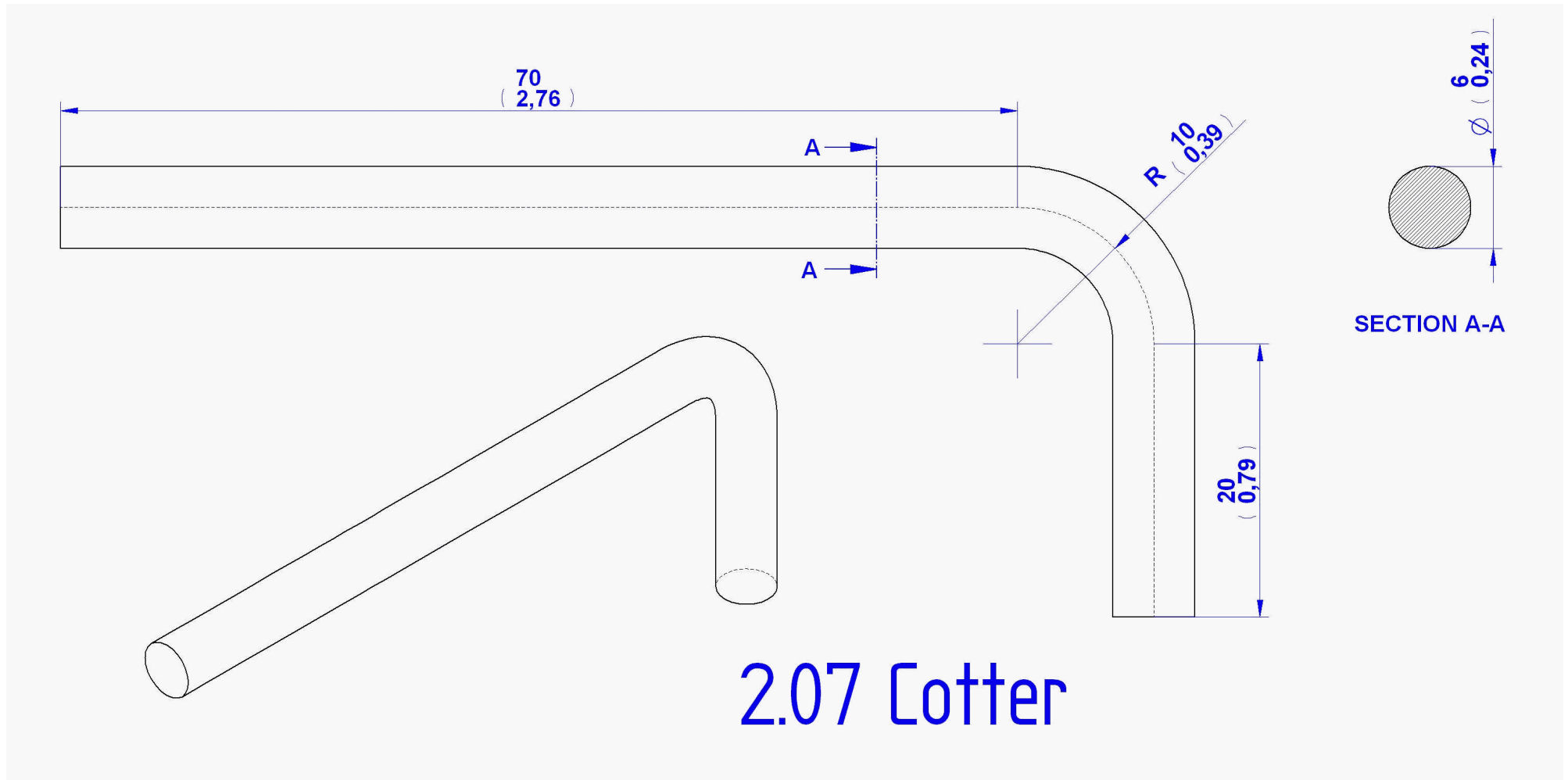

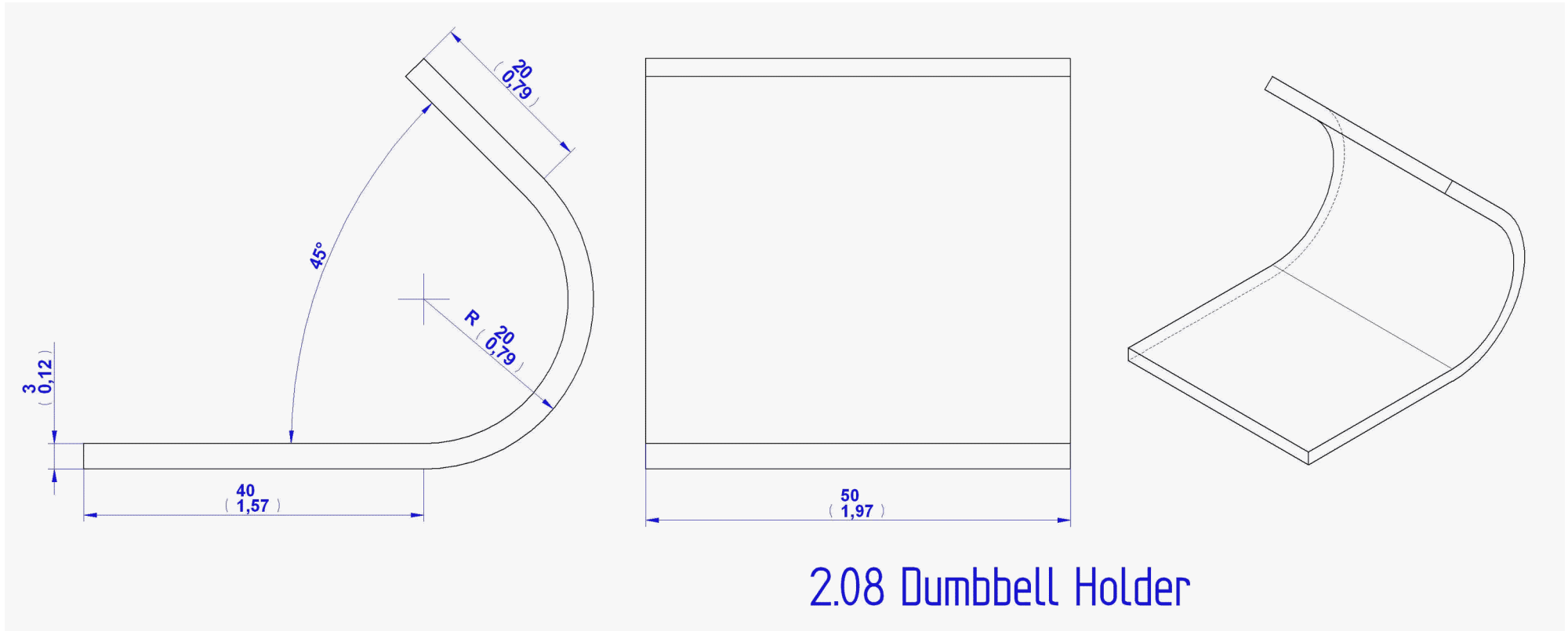

3. Weight set sub-assembly – Parts list and 2D documentation

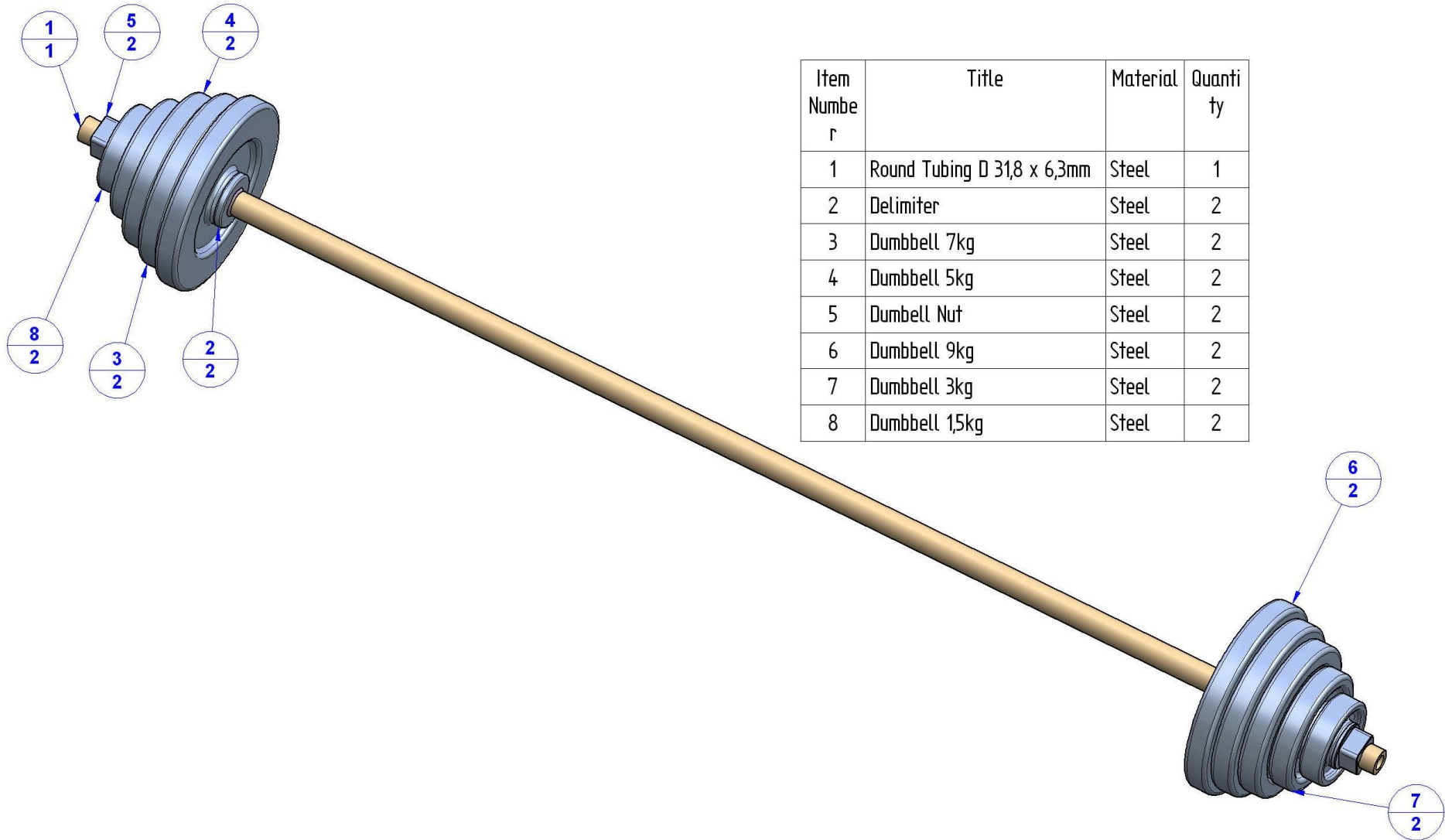

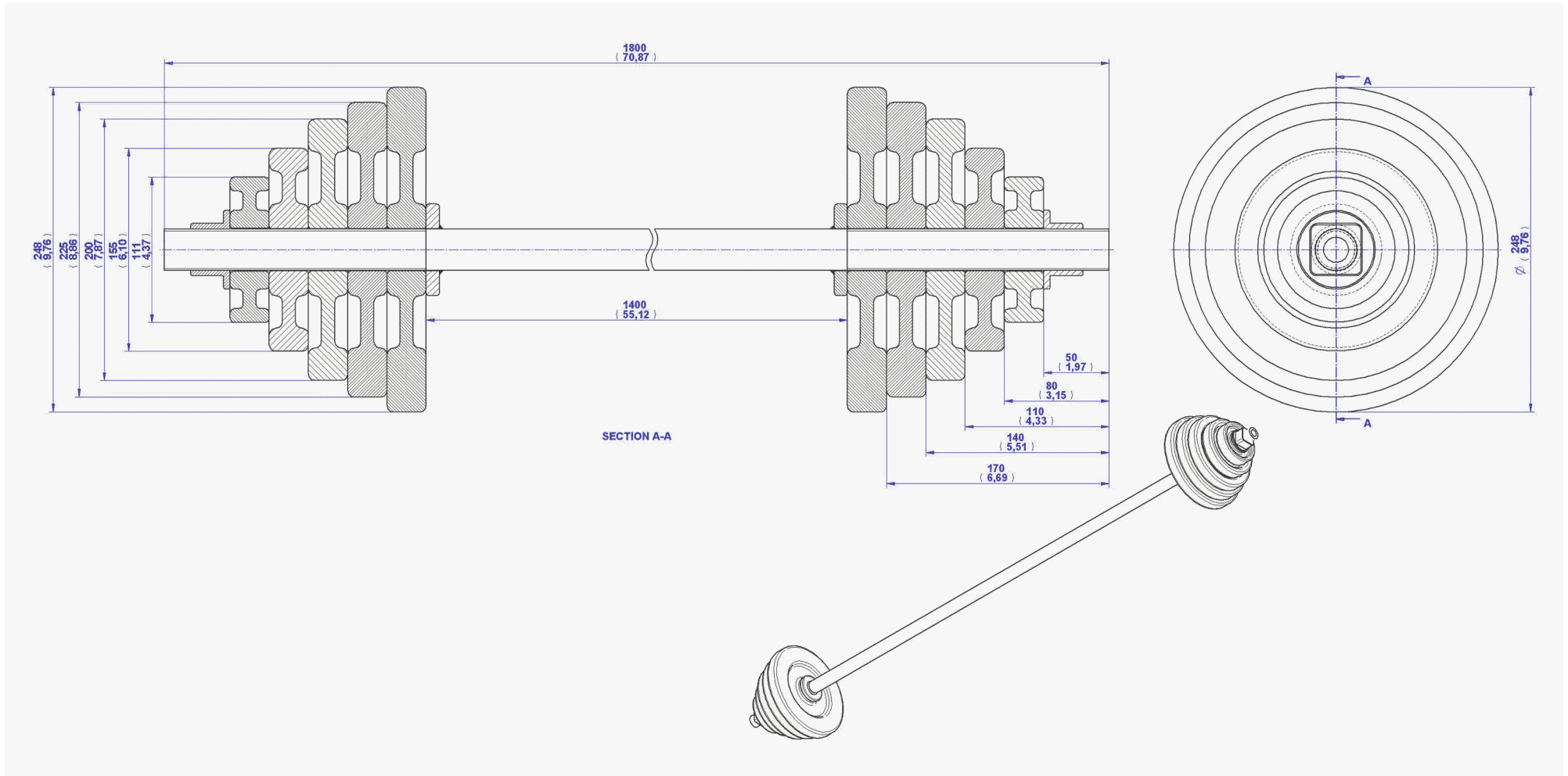

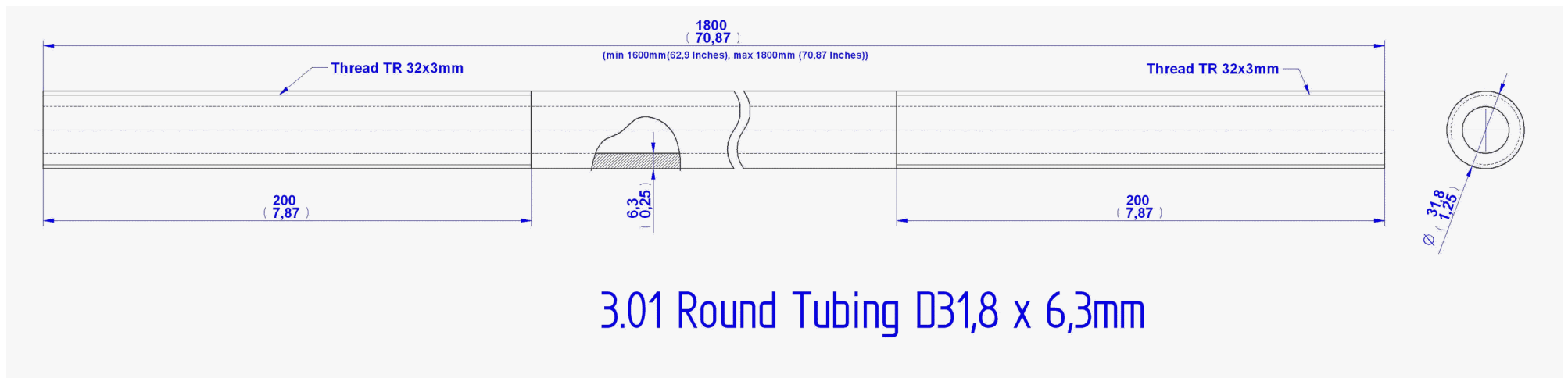

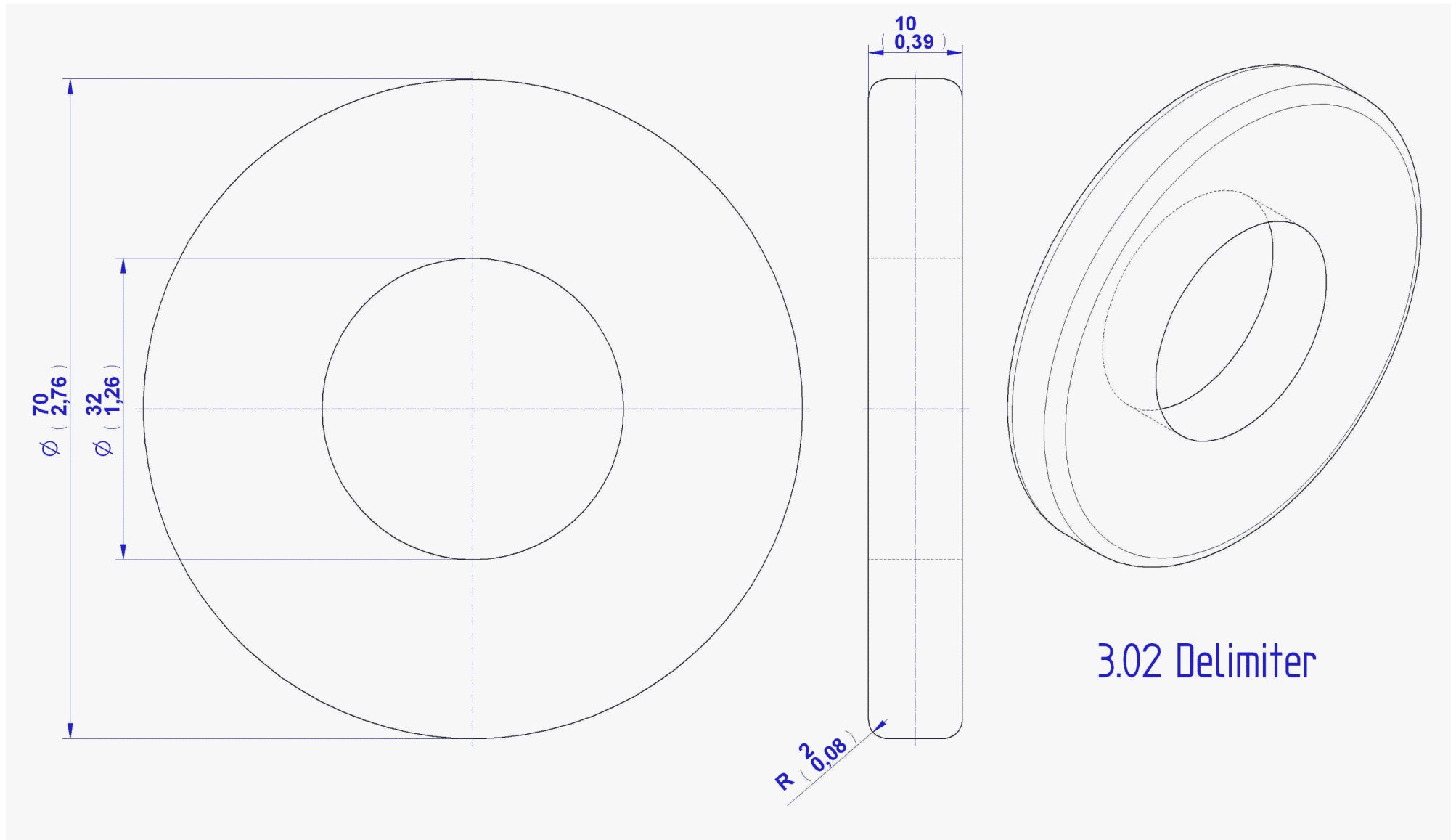

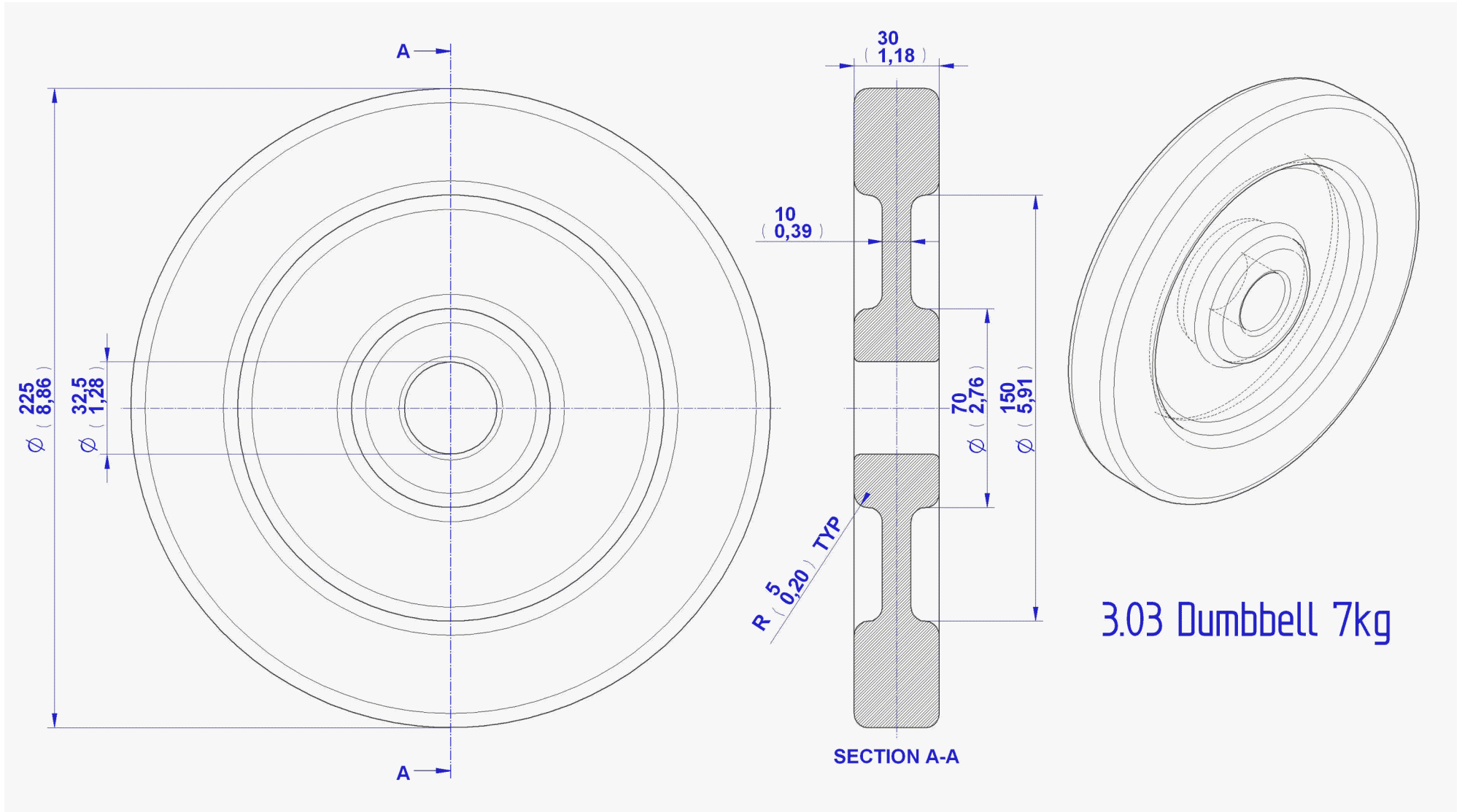

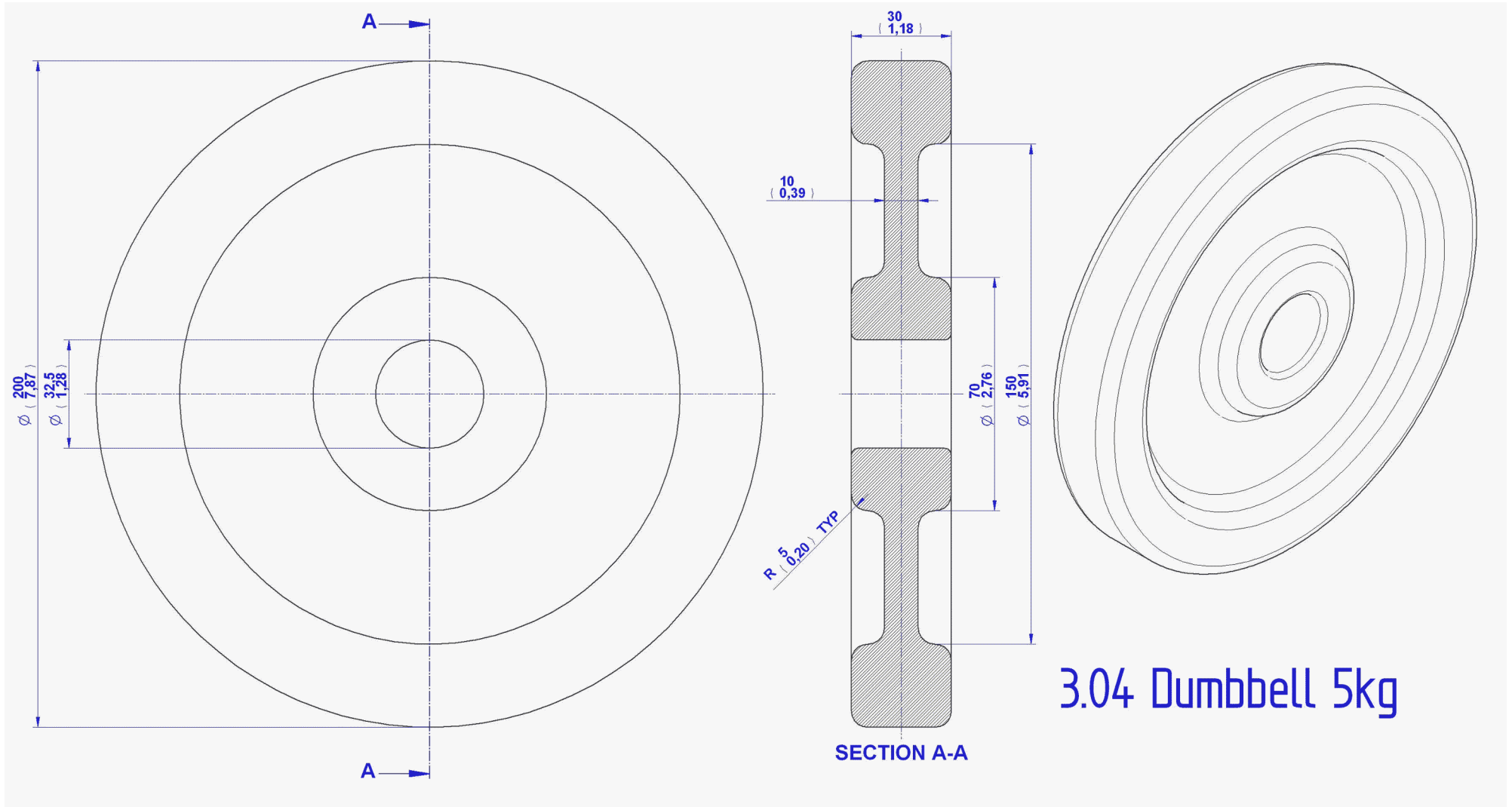

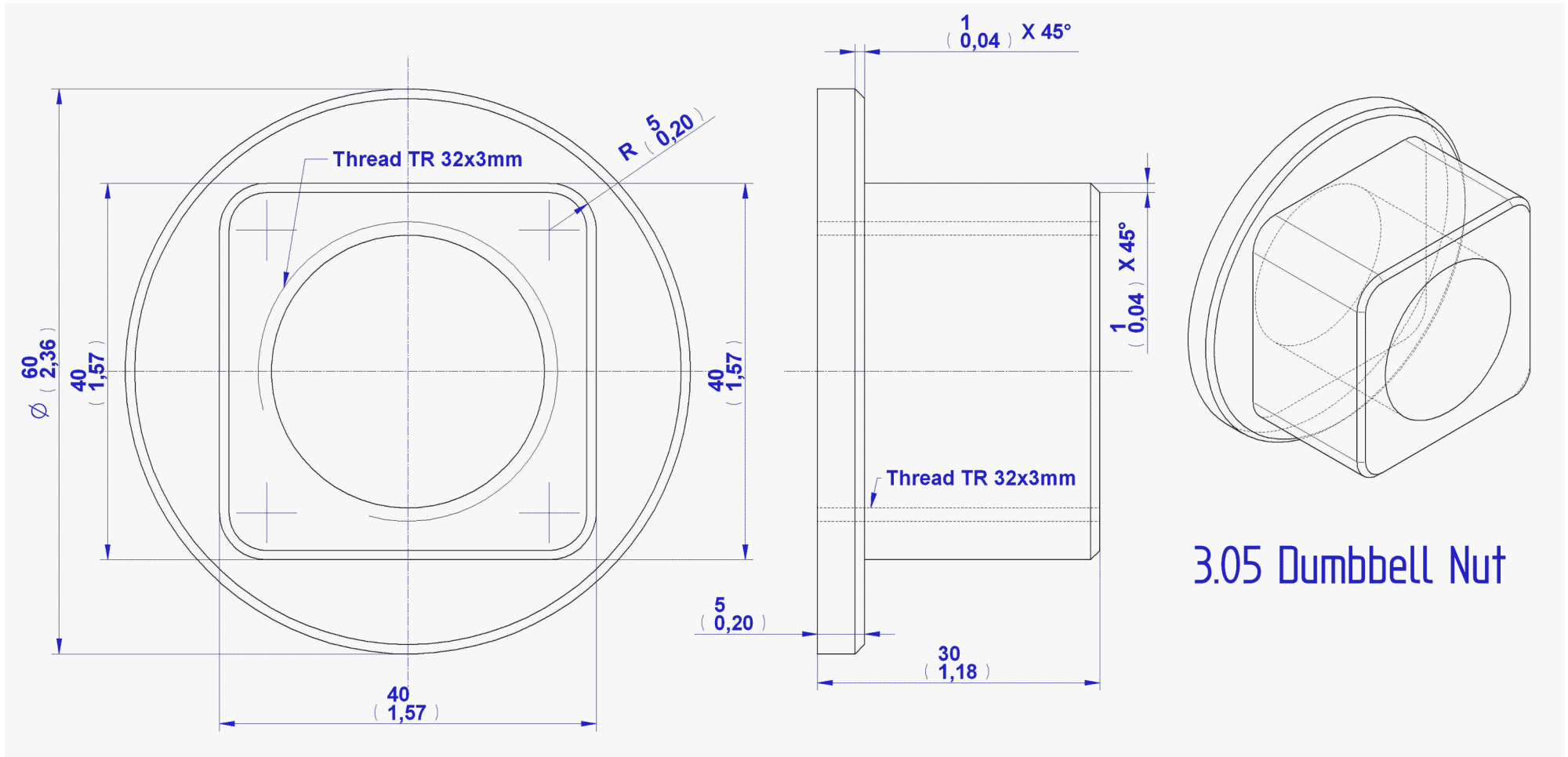

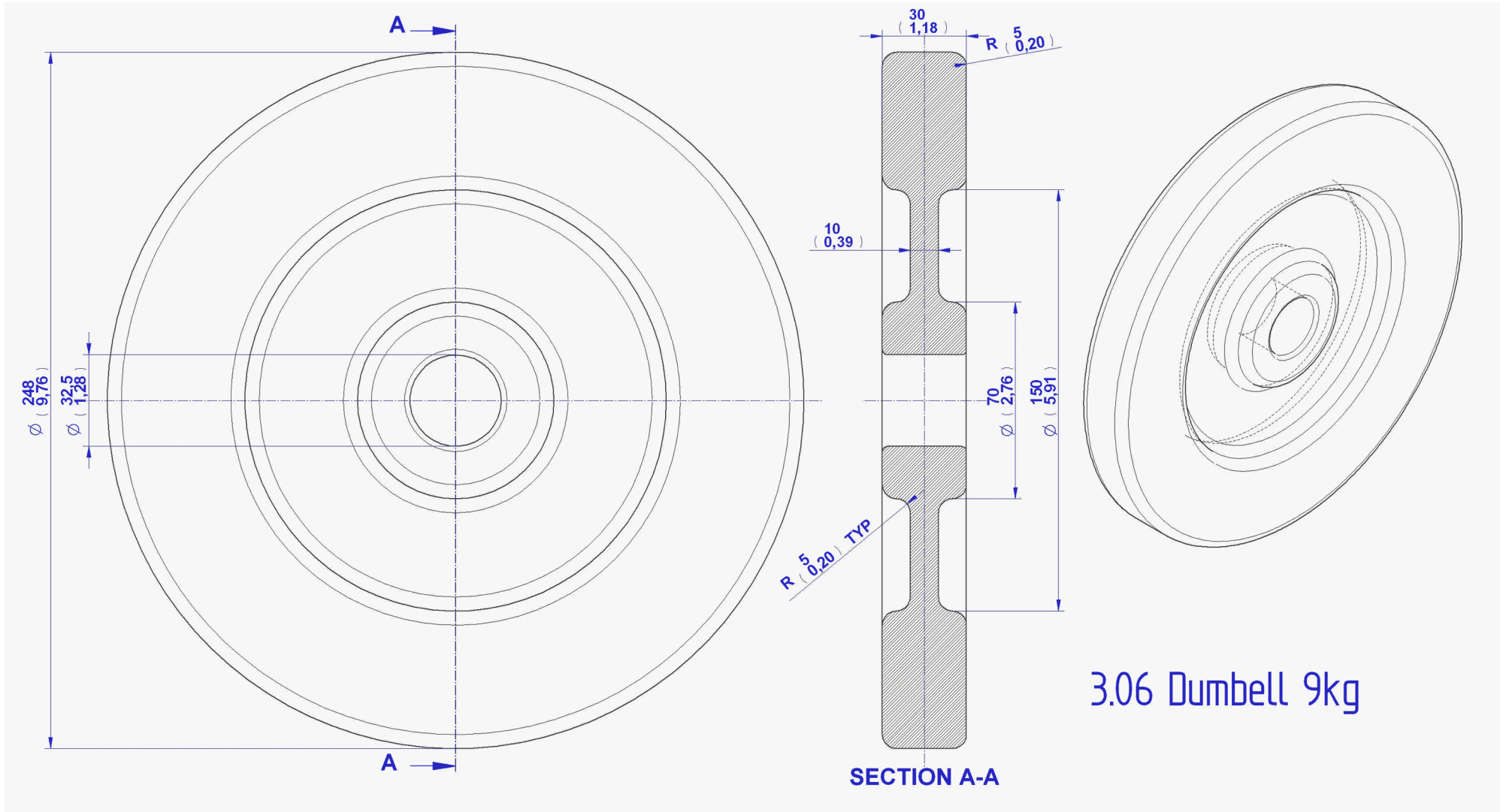

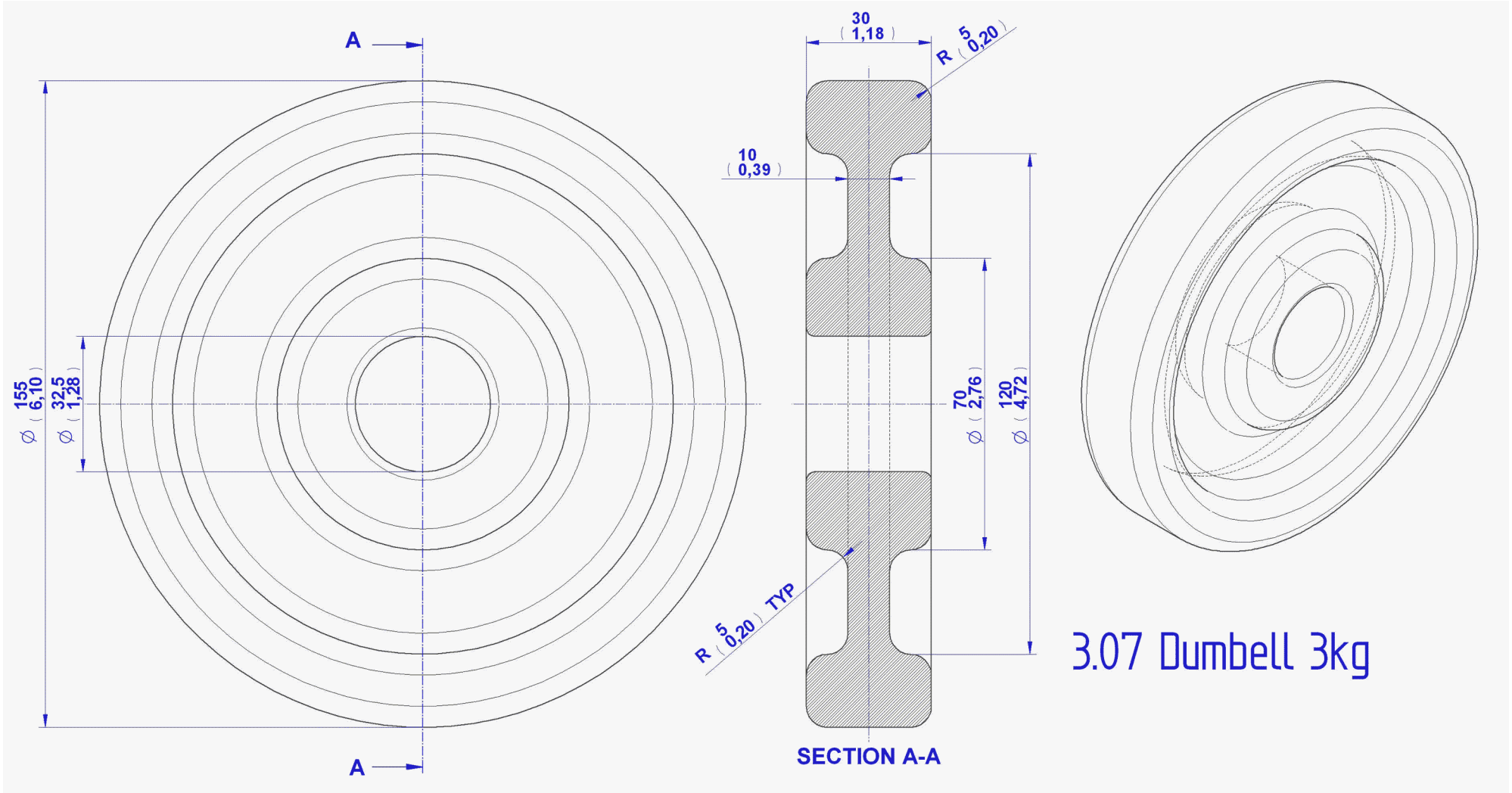

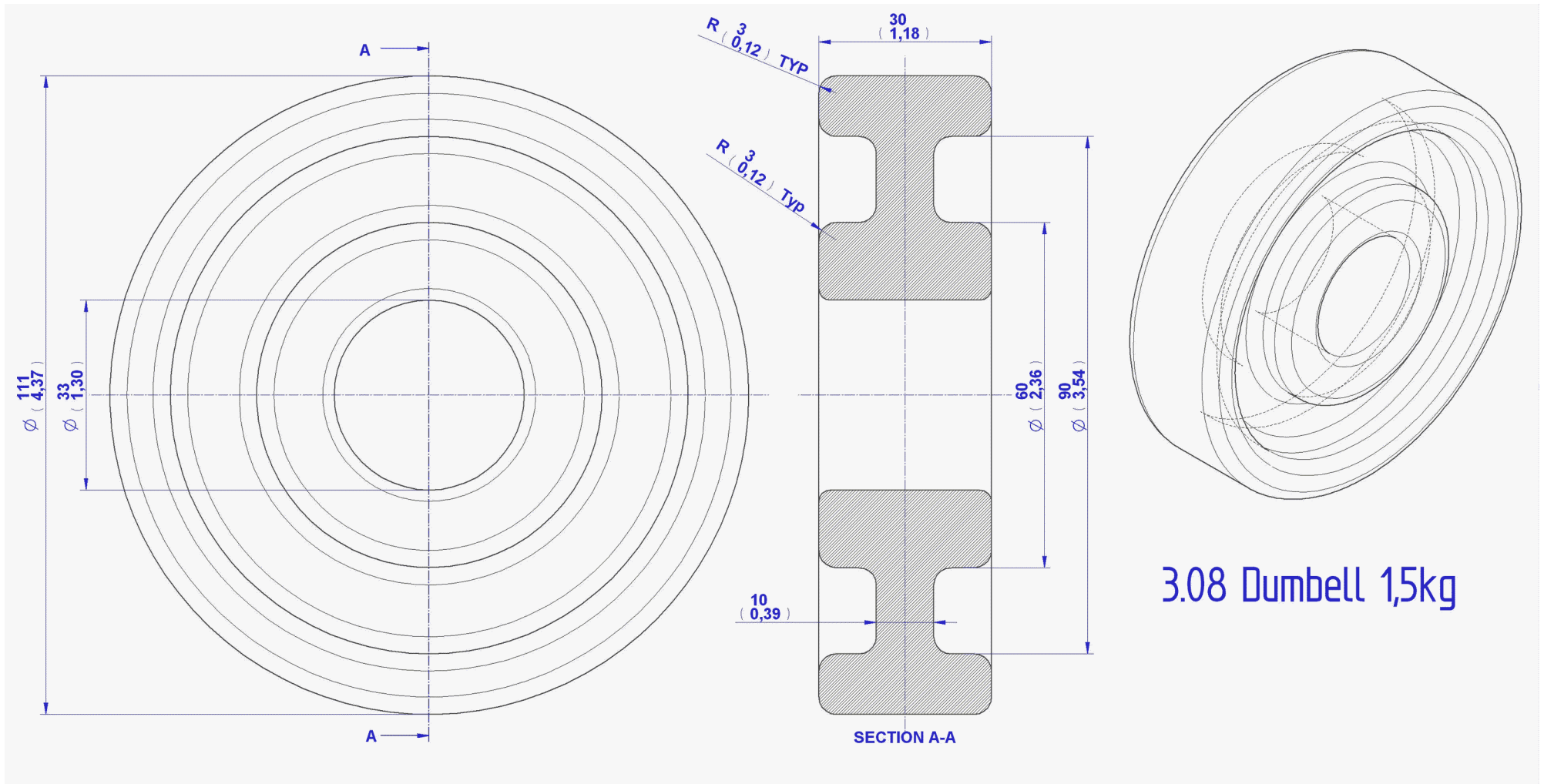

4. Leg developer sub-assembly – Parts list and 2D documentation

Item Number	Title	Material	Quantity	Category	Cut Length
1	Support	Steel	2		
2	Cover 40x40	Steel	2		
3	Square Tubing 40x40x2,9mm	Steel	1		445.00 mm
4	Square Tubing 40x40x2,9mm	Steel	1		119.45 mm
5	Square Tubing 40x40x2,9mm	Steel	1		87.28 mm
6	Square Tubing 40x40x2,9mm	Steel	1		273.84 mm
7	Square Tubing 40x40x2,9mm	Steel	1		159.35 mm
8	Round Tubing D25,4 x 3,2mm	Steel	2		400,00mm
9	Round Tubing D25,4 x 3,2mm	Steel	1		280,00mm
10	Cover D25.4mm	Steel	5		
11	Cilinder	Steel	1		
12*	Sheet Support	Steel	1		
13	Axle	Steel	1		
14	Spring Lock Washer A-20	Steel	1	Standard Part	
15	Hexagon Nut M20	Steel	1	Standard Part	
16	Spring lock washer A - 8	Steel	2	Standard Part	
17	Hexagon Nut M8	Steel	2	Standard Part	
18	Hexagon bolt M8x70	Steel	2	Standard Part	

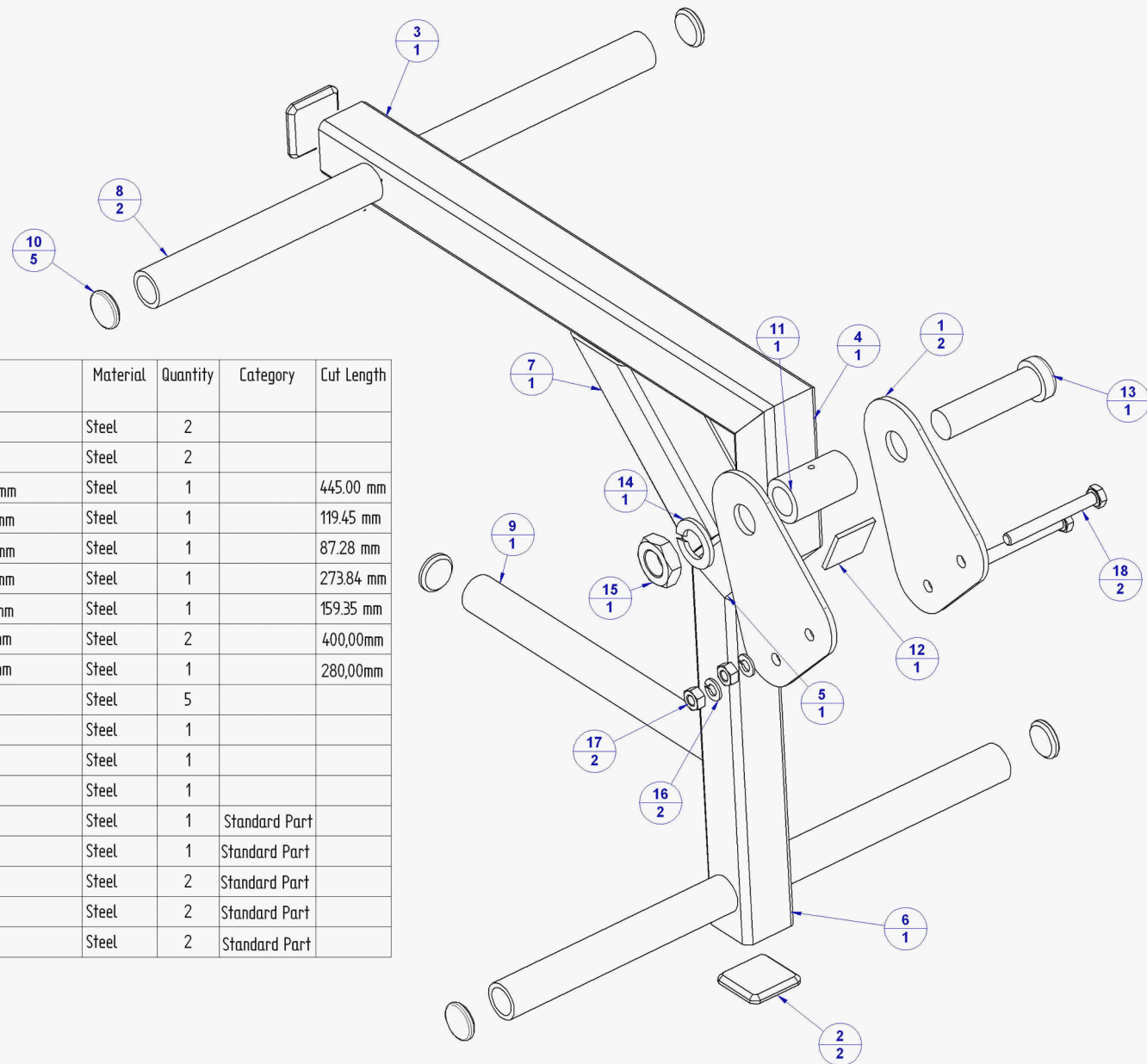

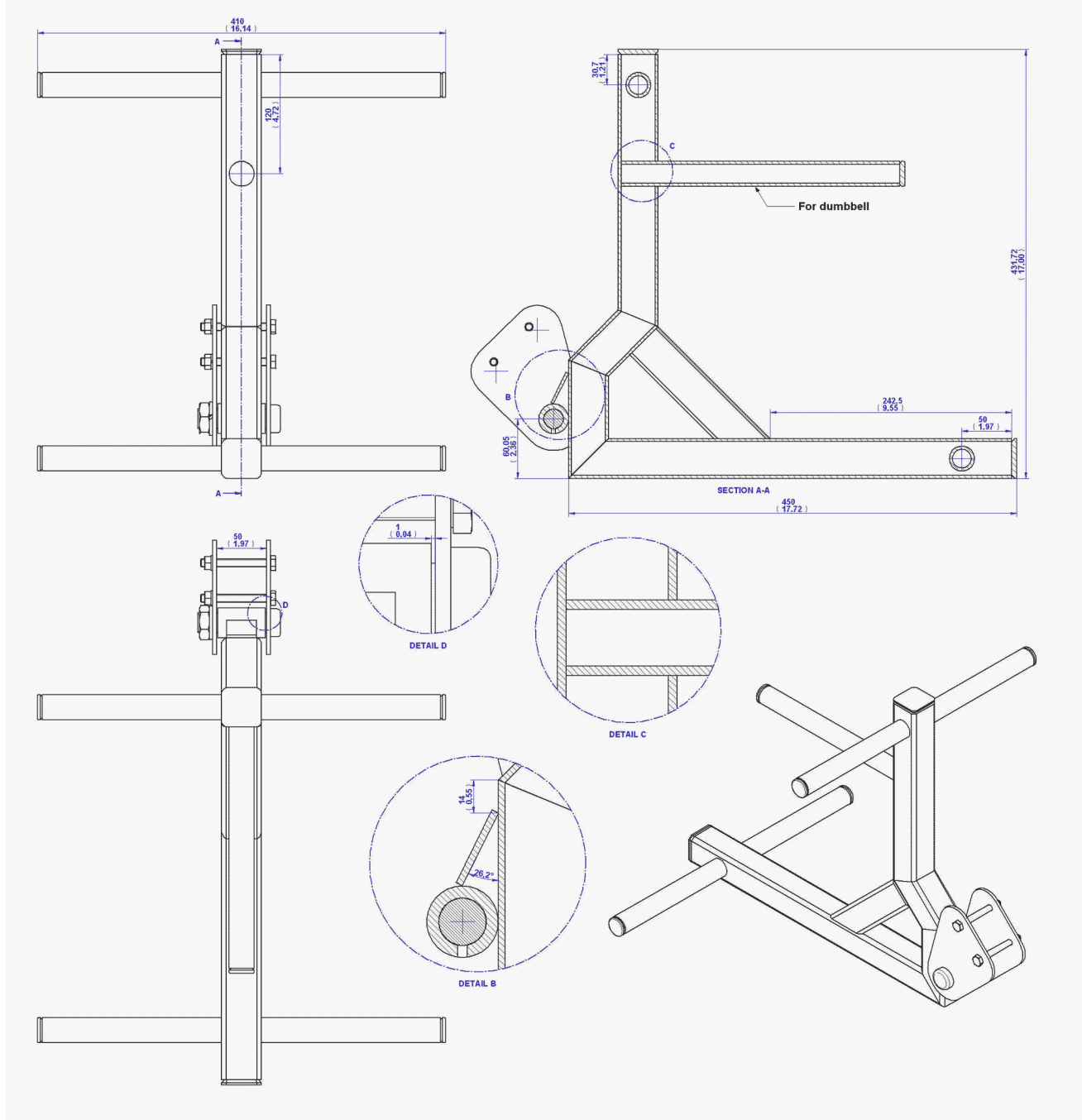

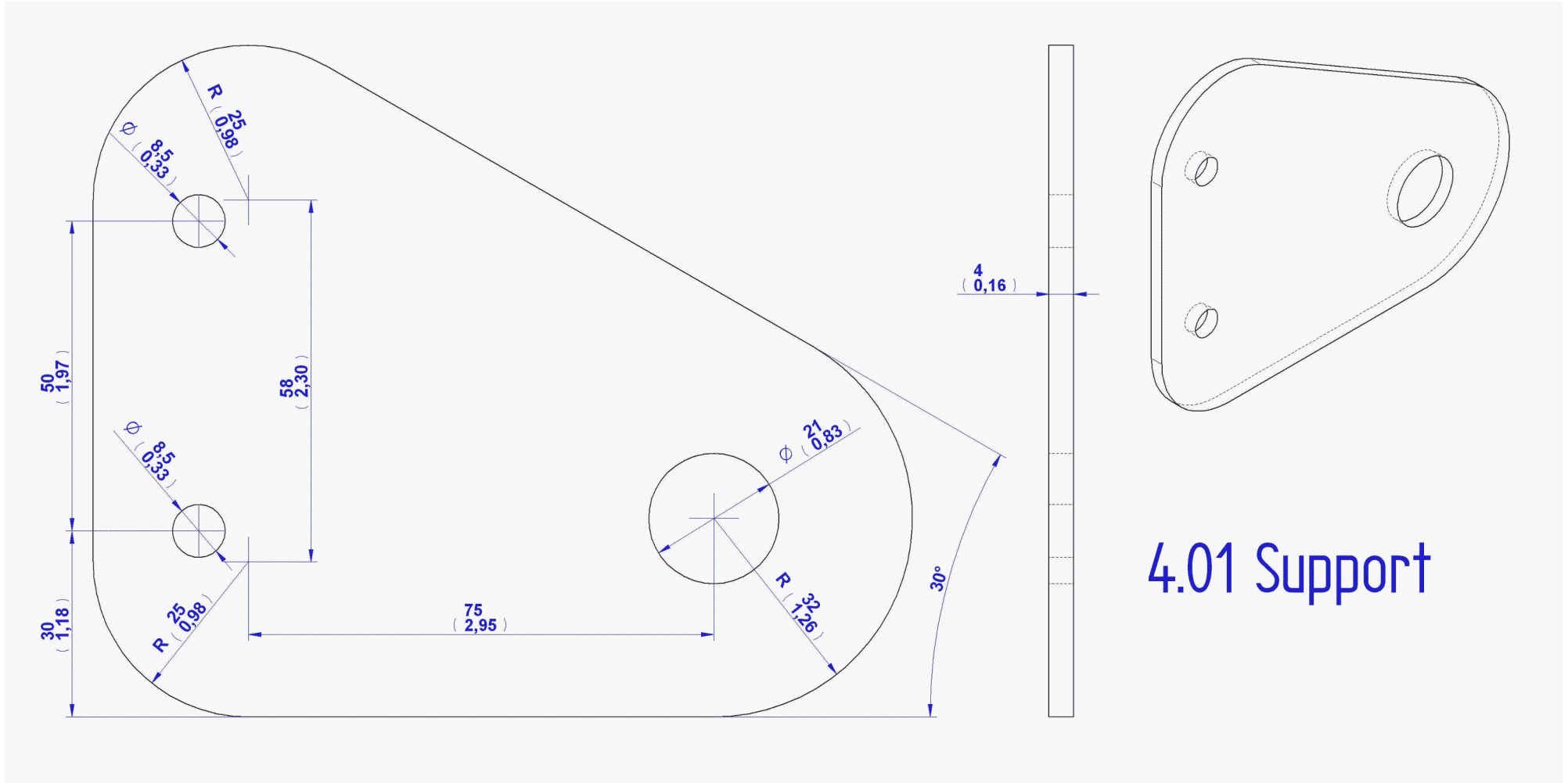

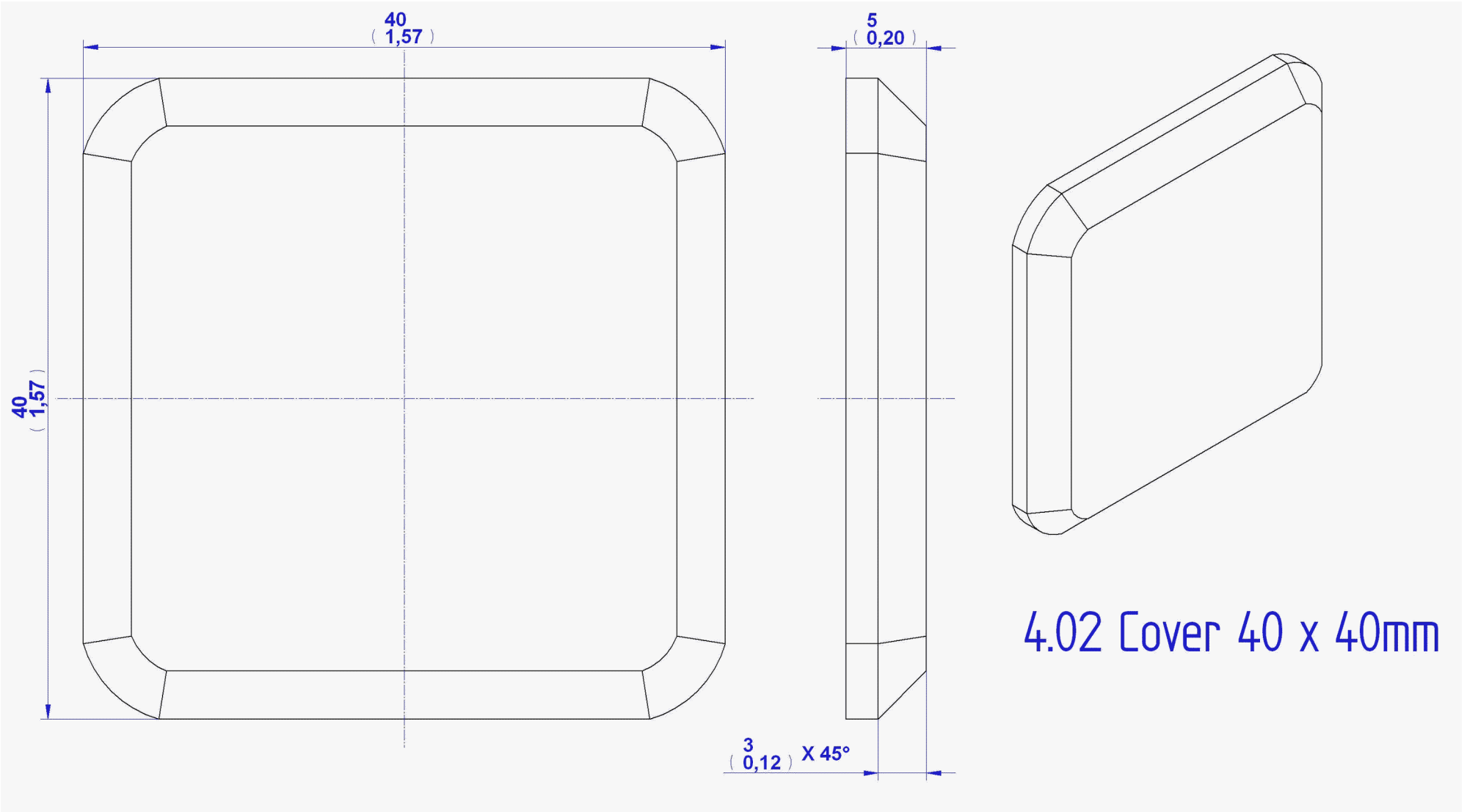

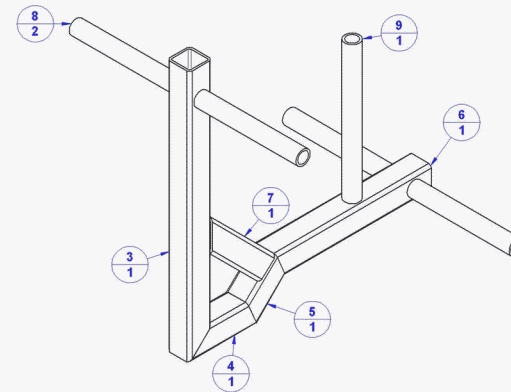
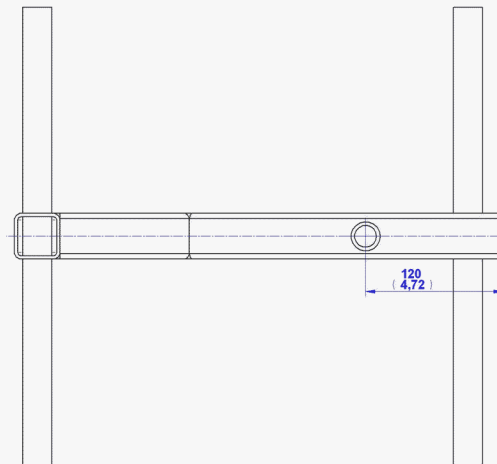
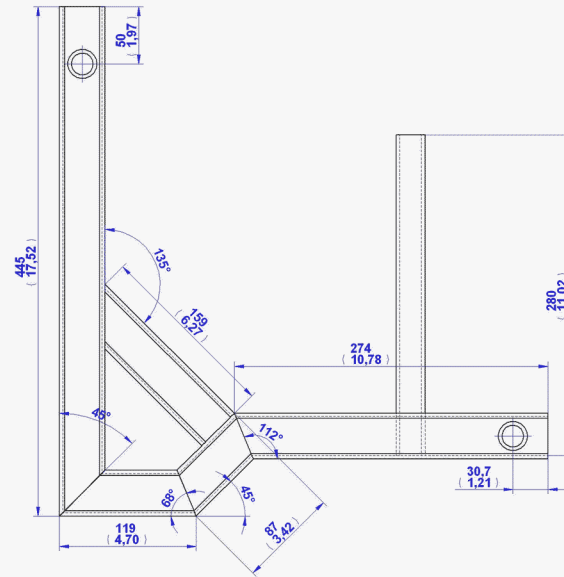

FRAME COMPONENTS
4.03, 4.04, 4.05, 4.06, 4.07, 4.08, 4.09

Item Number	Title	Quantity	Cut Length
3	Square Tubing 40 x 40 x 2.9mm	1	445.00 mm
4	Square Tubing 40 x 40 x 2.9mm	1	119.45 mm
5	Square Tubing 40 x 40 x 2.9mm	1	87.28 mm
6	Square Tubing 40 x 40 x 2.9mm	1	273.84 mm
7	Square Tubing 40 x 40 x 2.9mm	1	159.35 mm
8	Round Tubing D25.4 x 3.2mm	2	400.00mm
9	Round Tubing D25.4 x 3.2mm	1	280.00mm

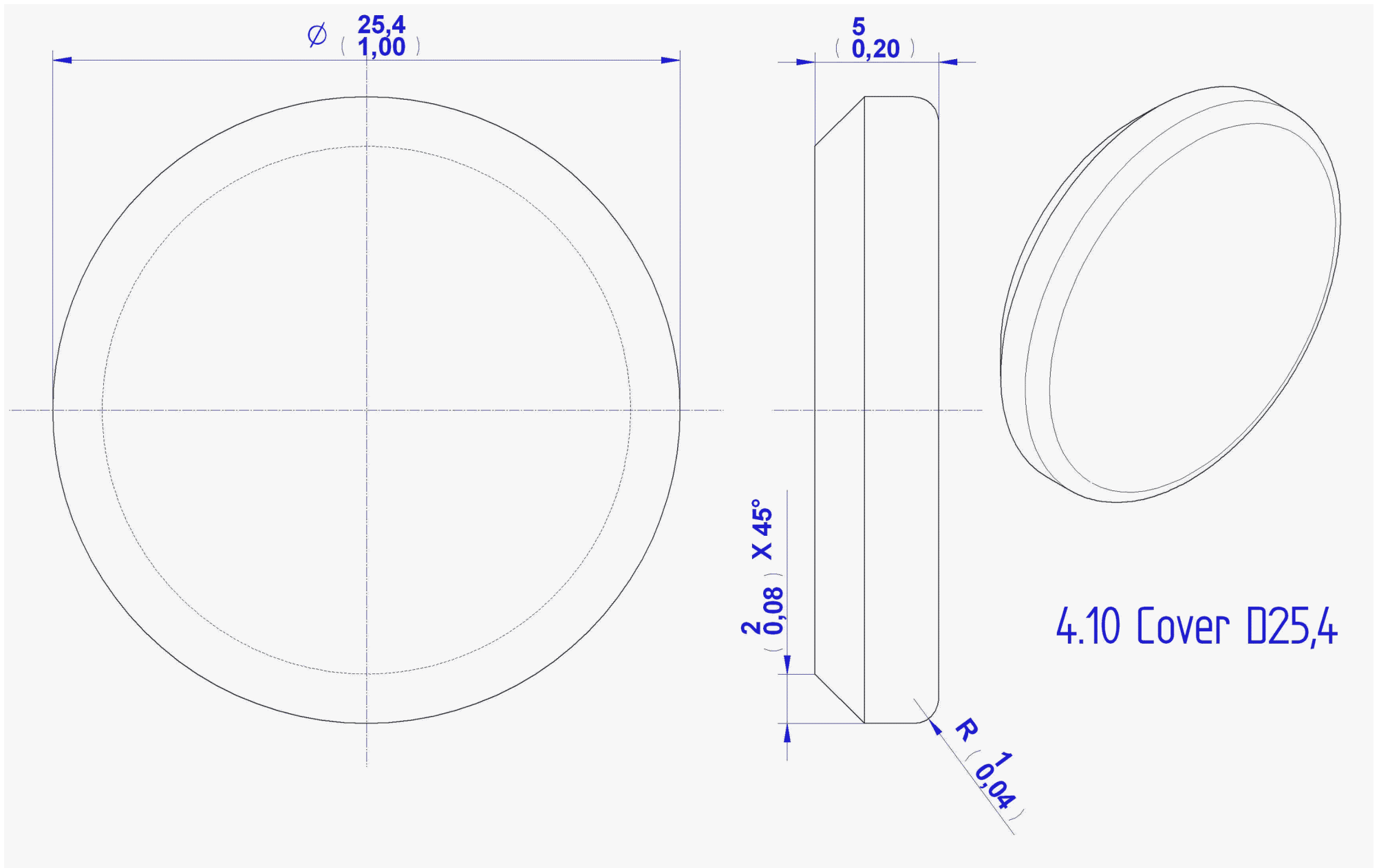

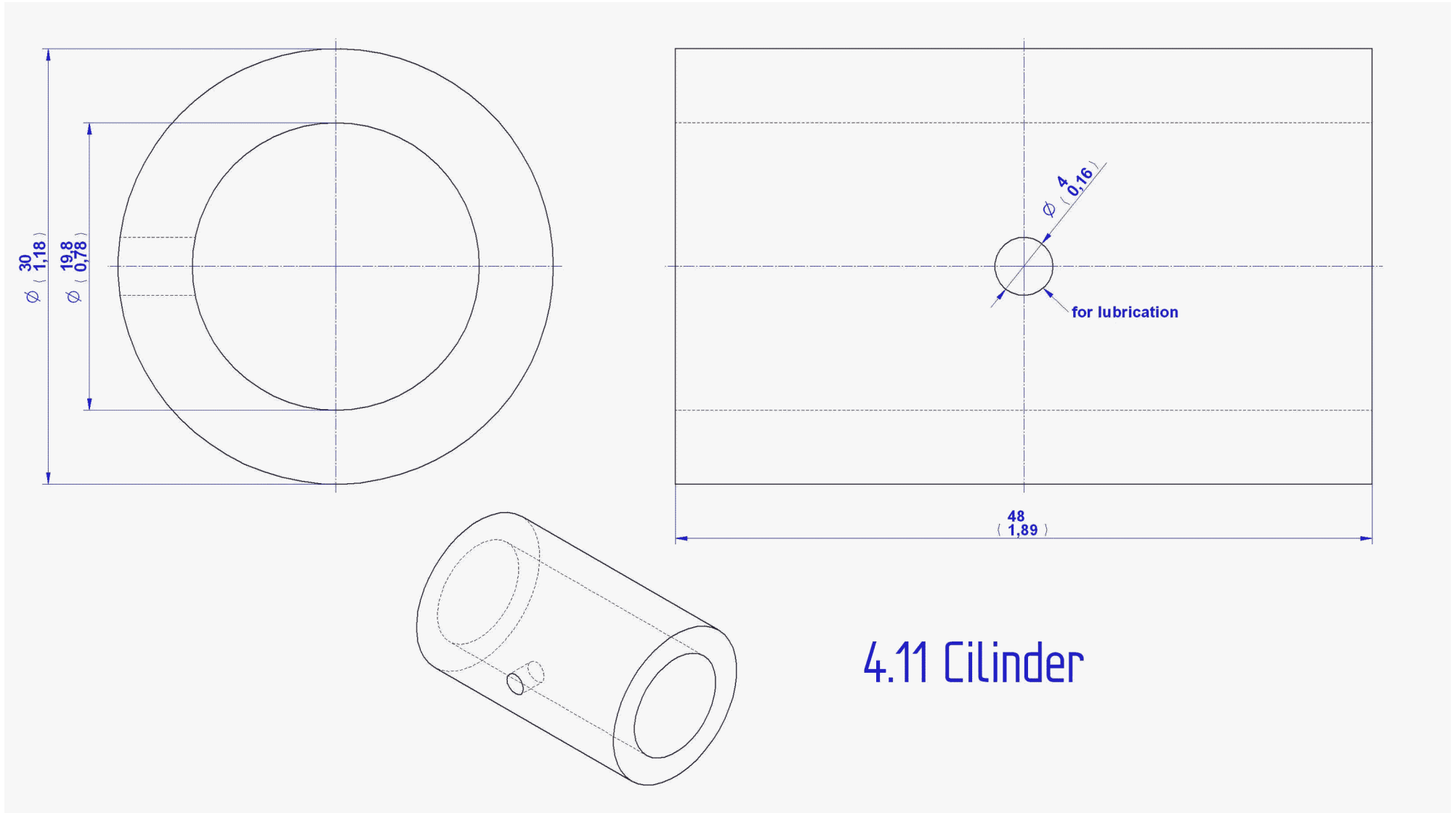

4.11 Cilinder

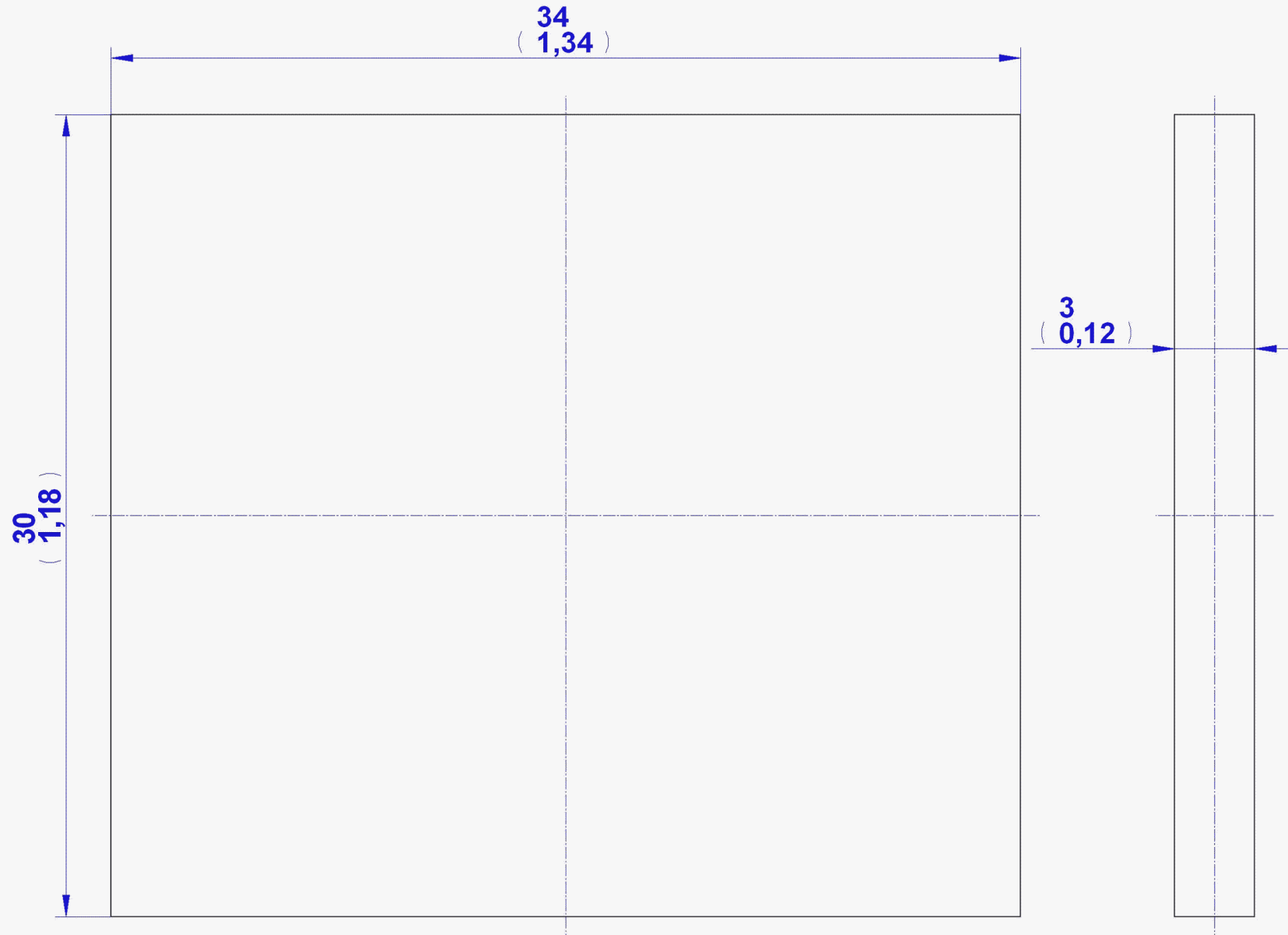

4.12 Sheet Support

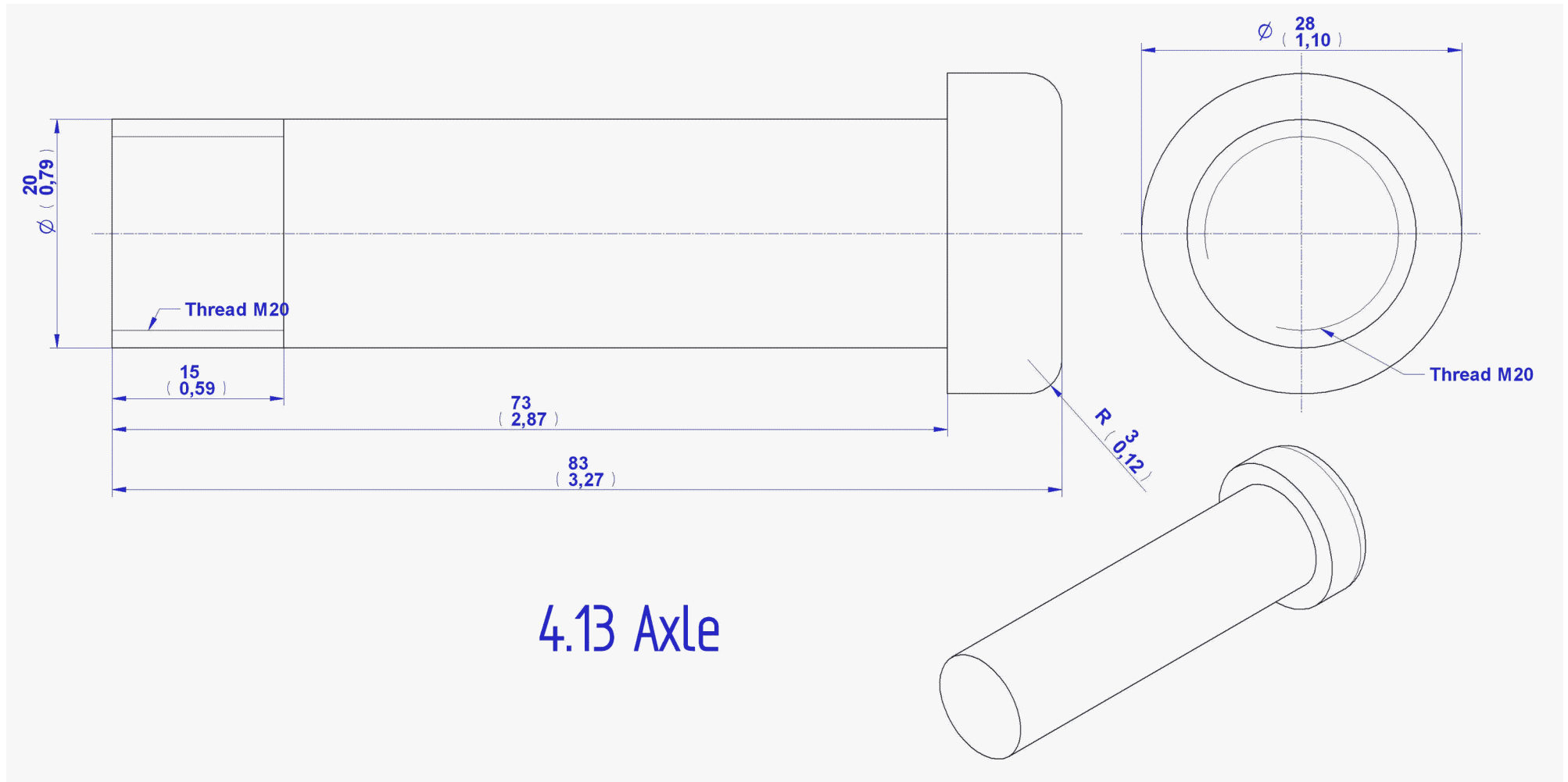

4.13 Axle

Standard Parts

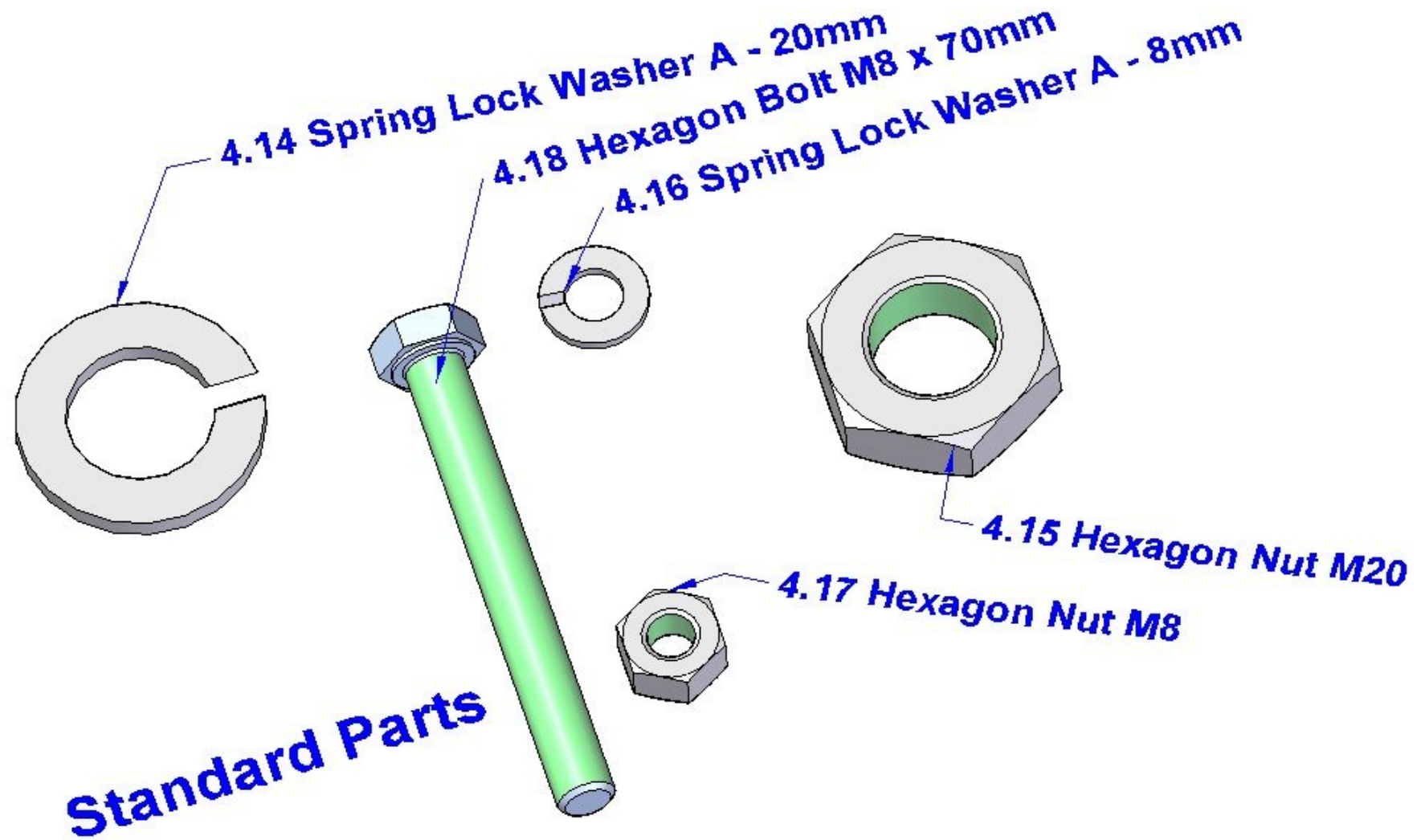

Assemblage images

1. Flat bench sub-assembly

1.

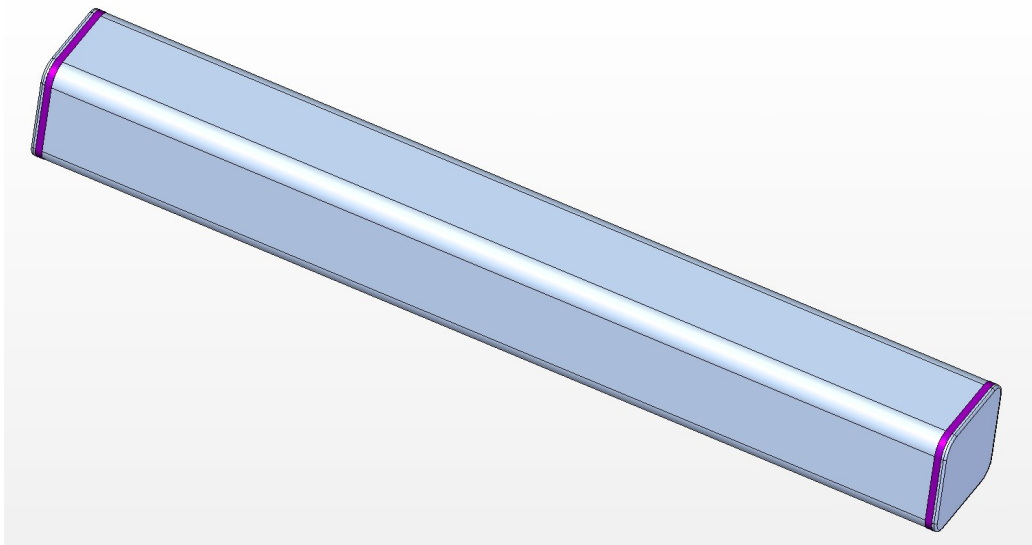
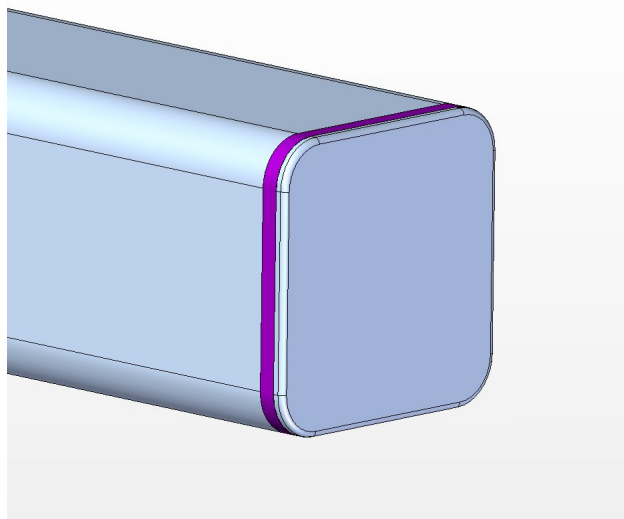
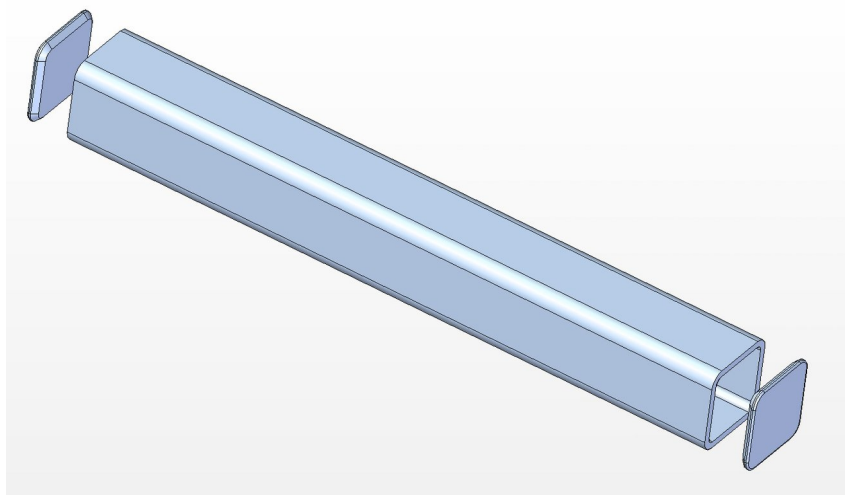

2.

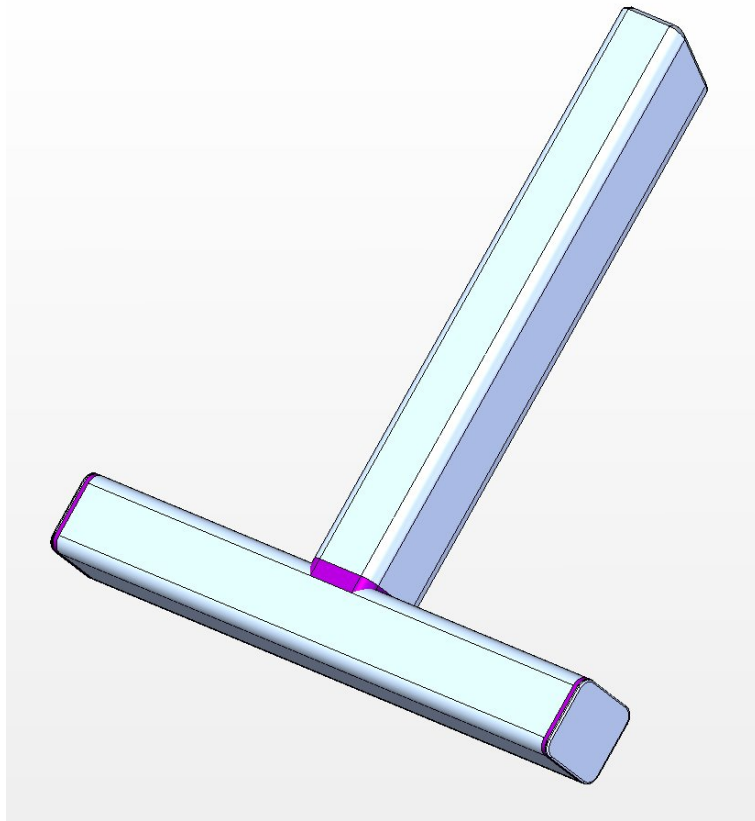
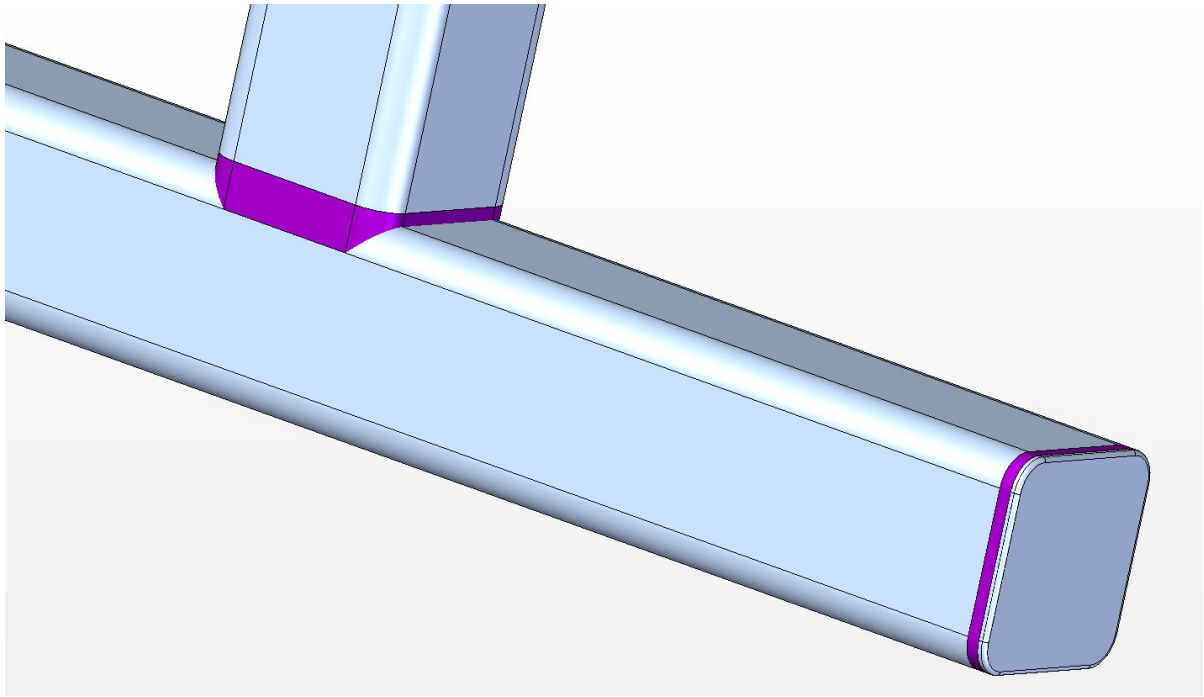

3.

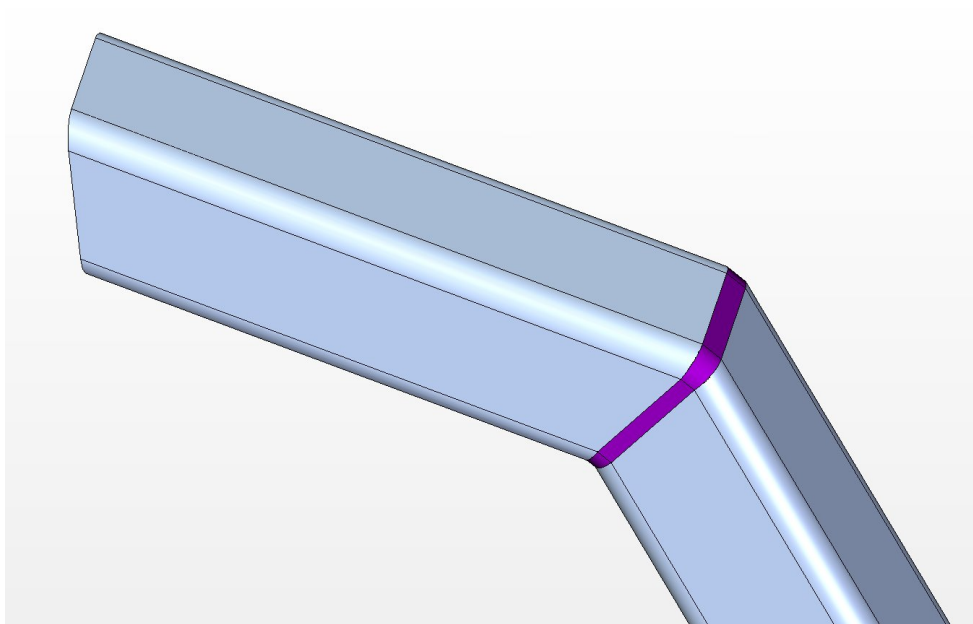
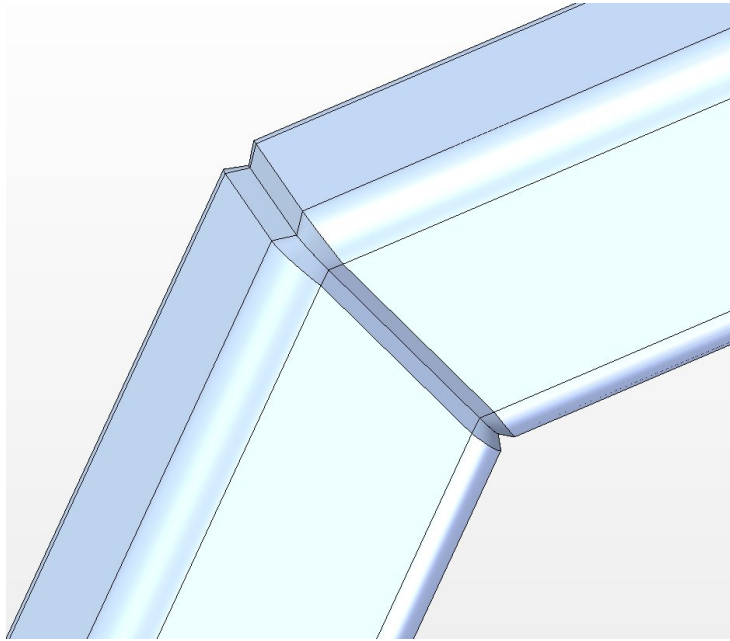

4.

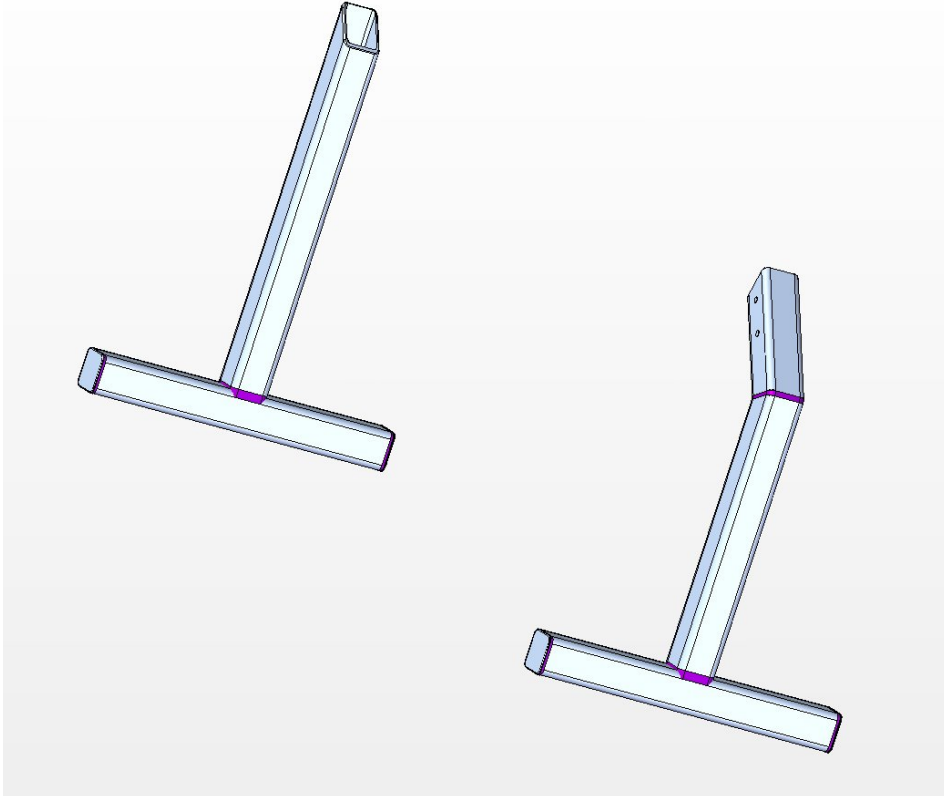
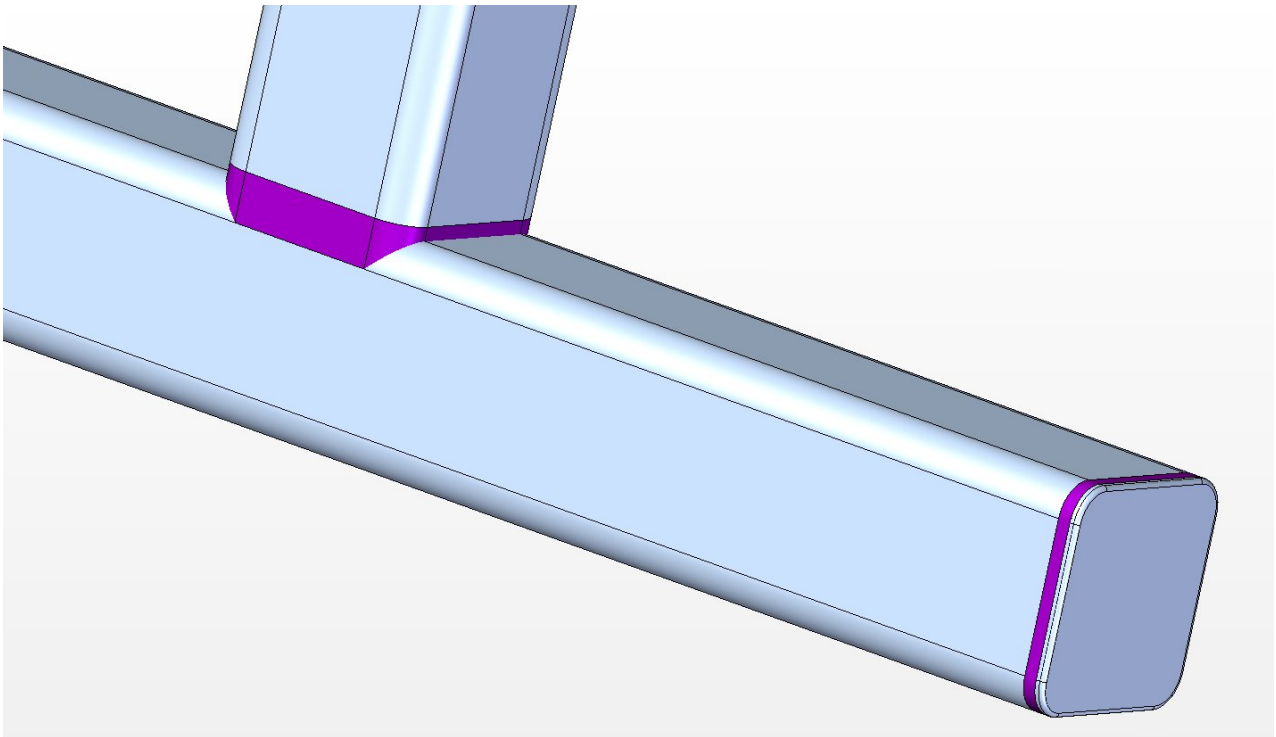

5.

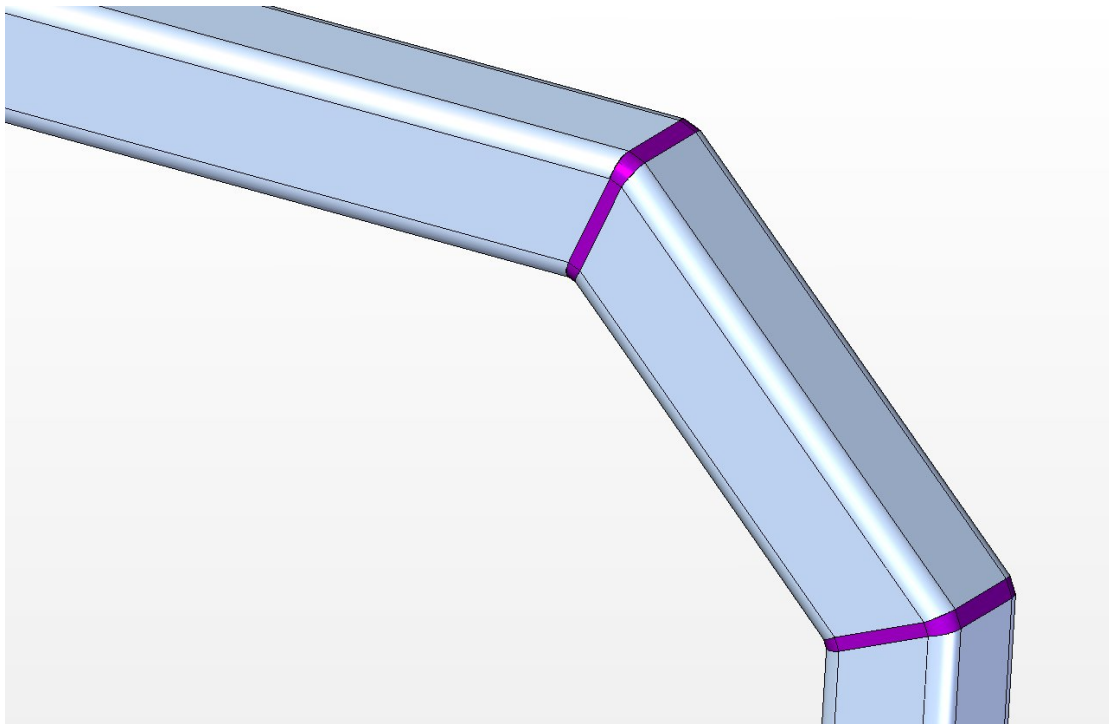
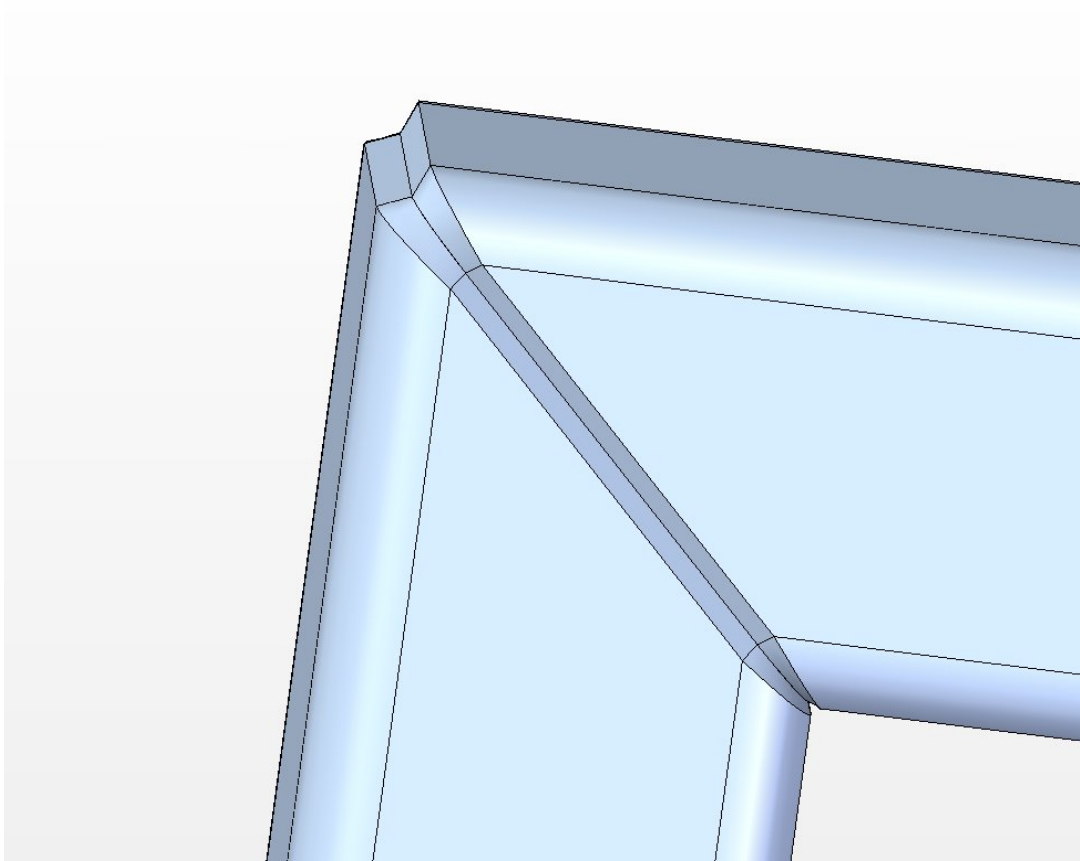

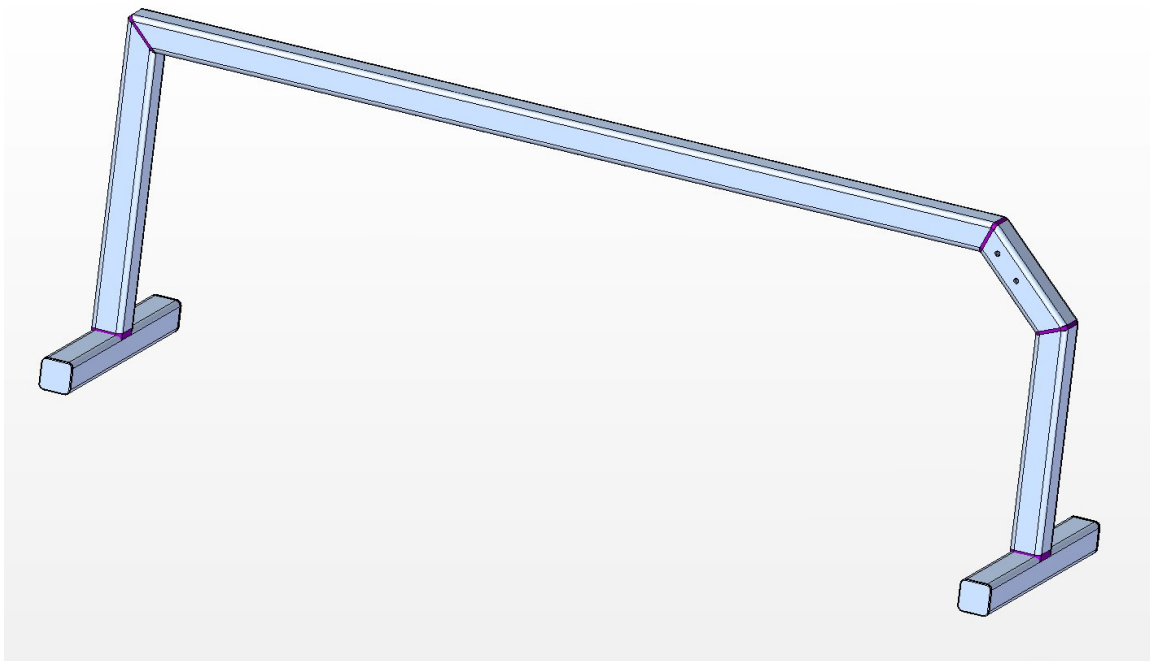
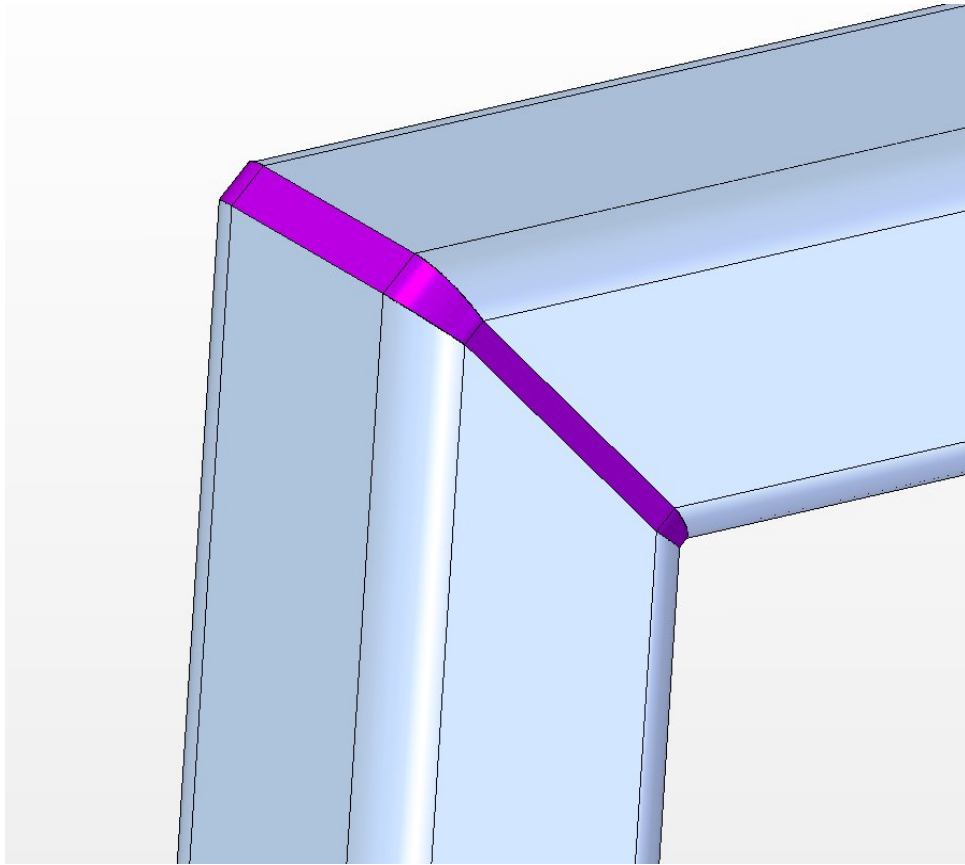

6.

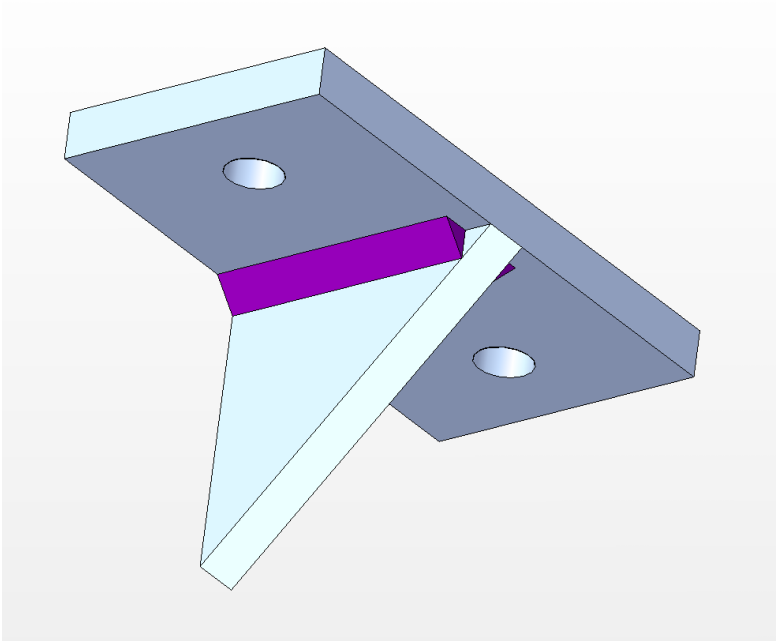

7.

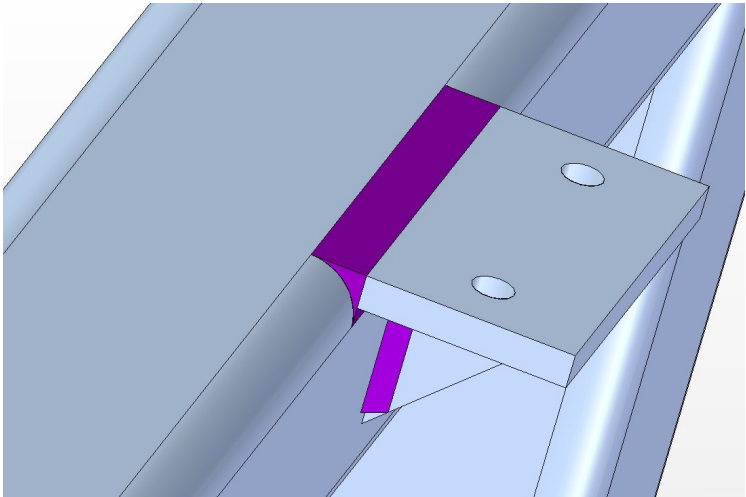
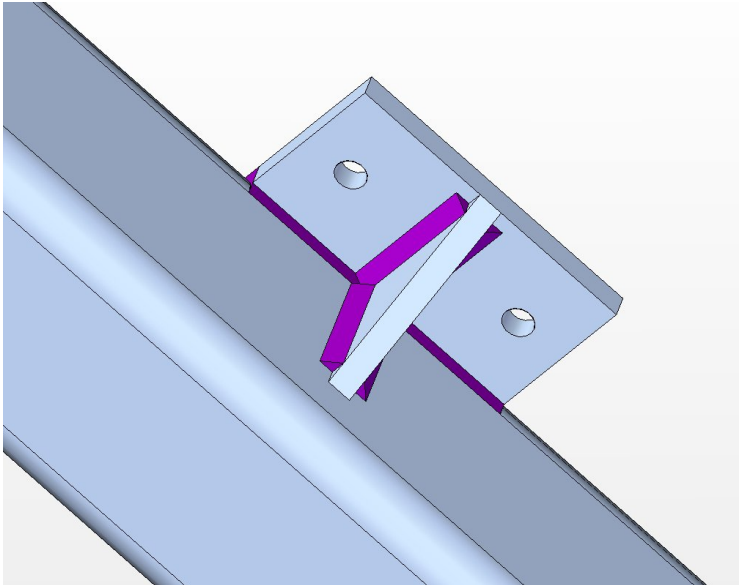

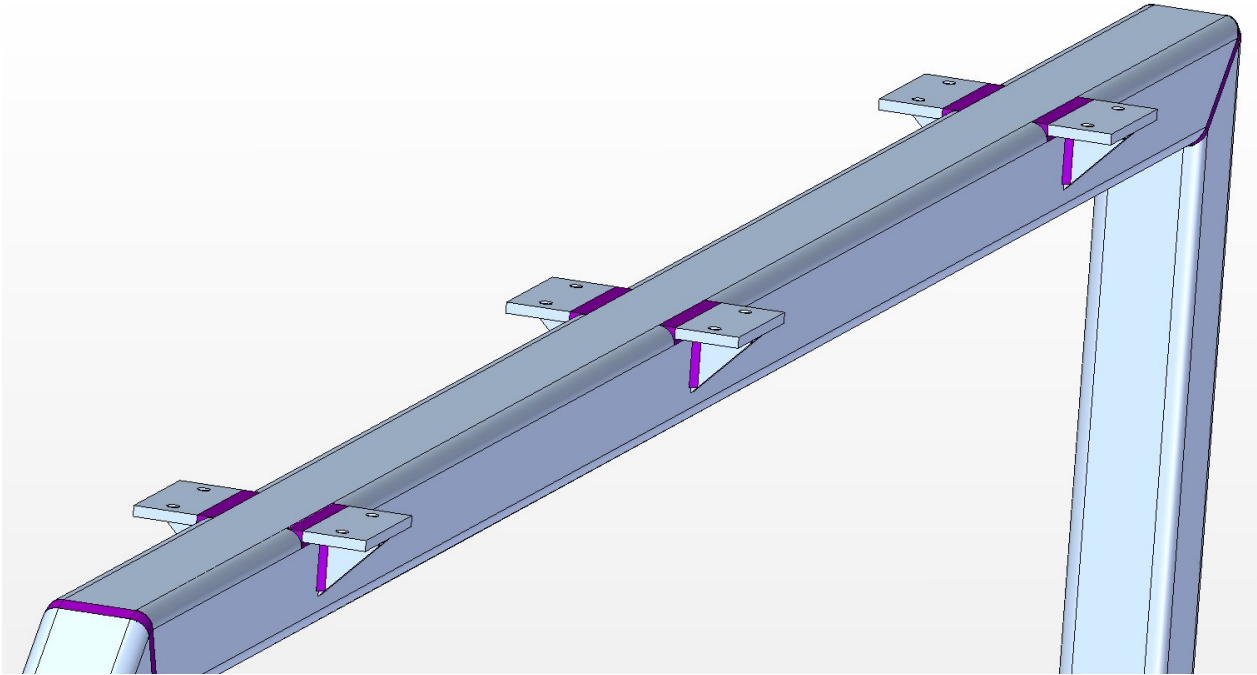

8.

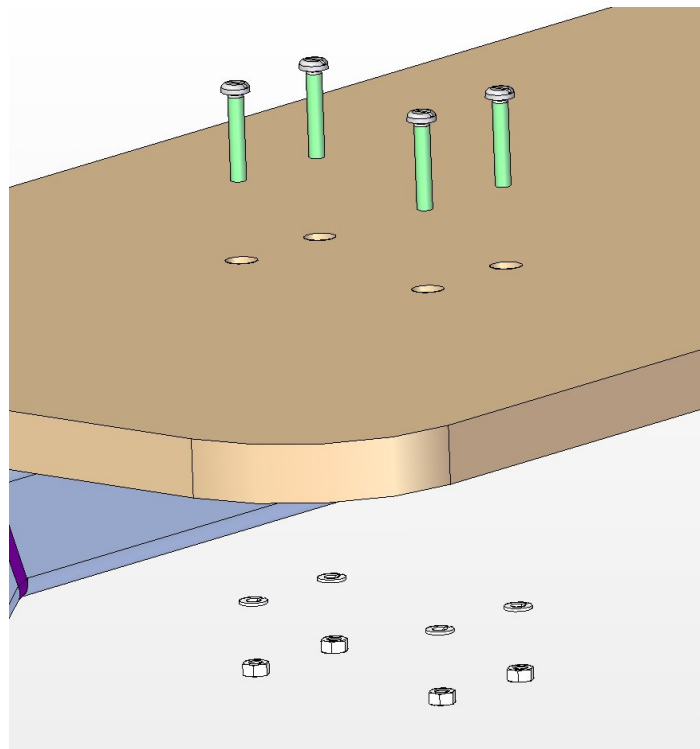

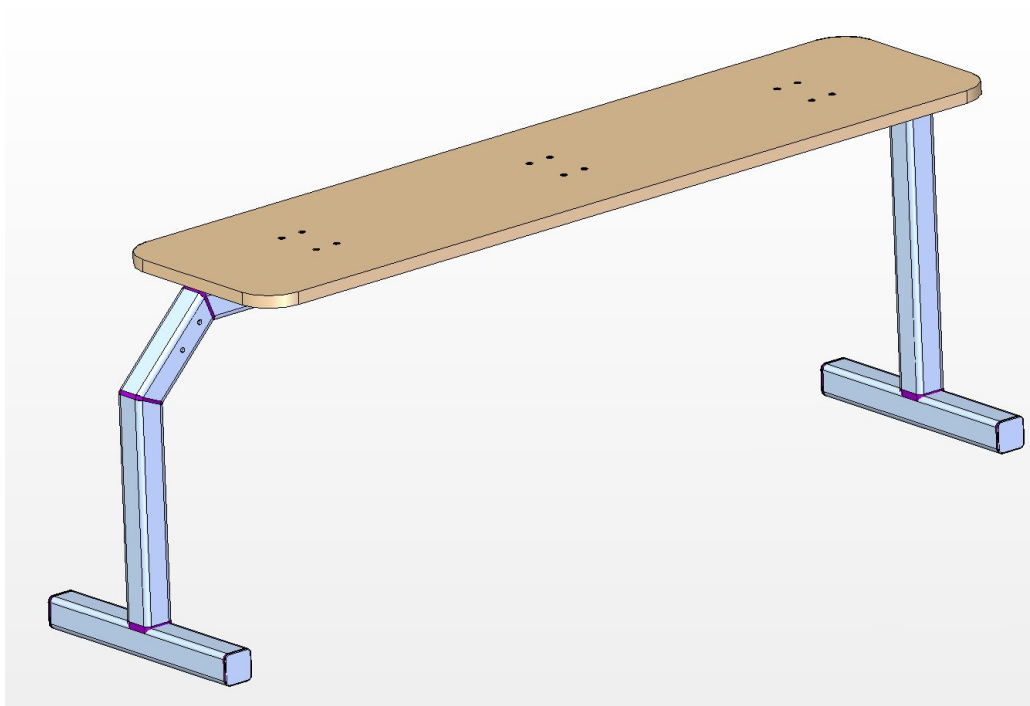
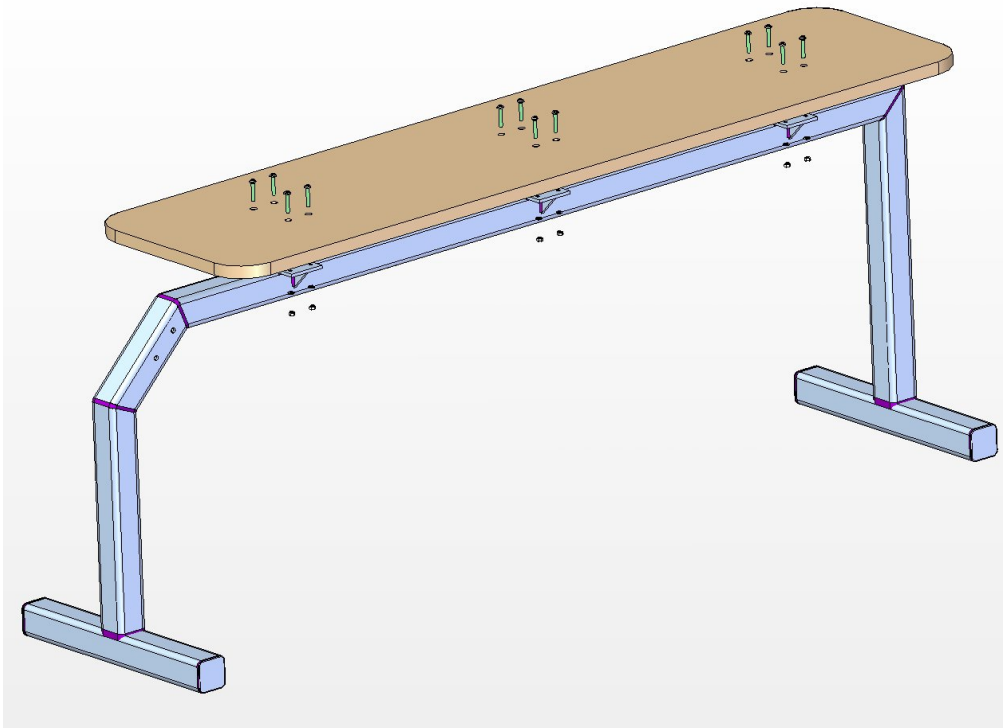

2. Stand sub-assembly

1.

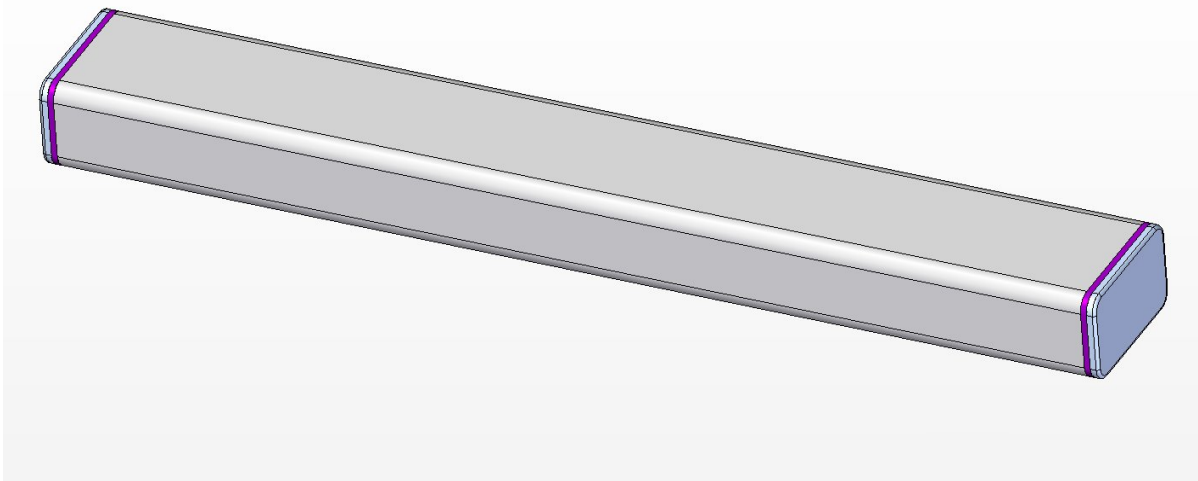
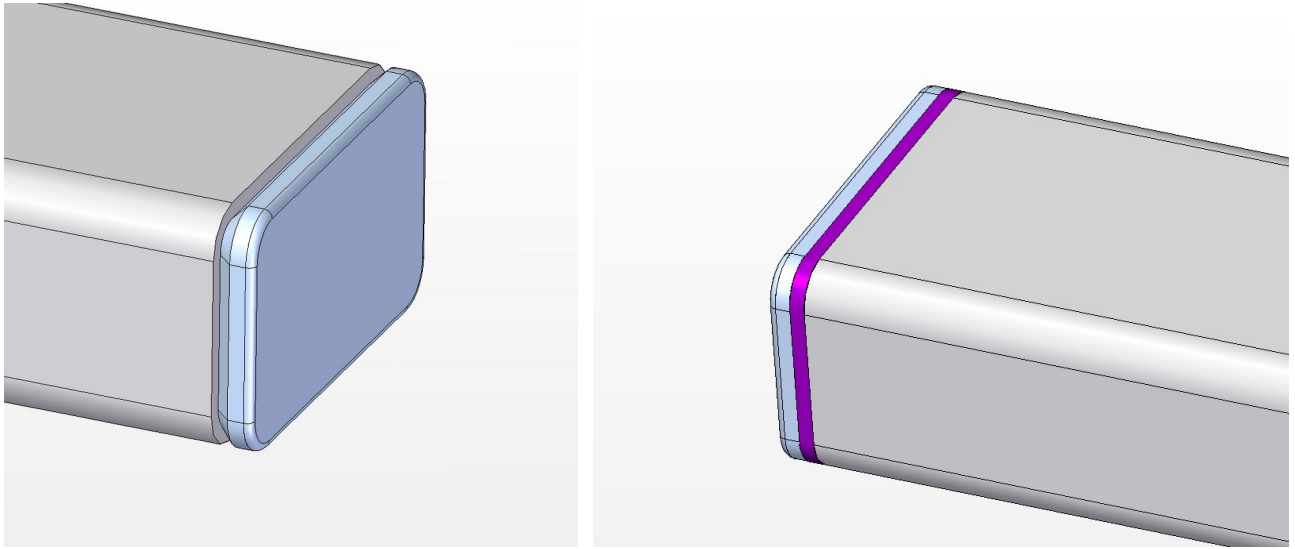

2.

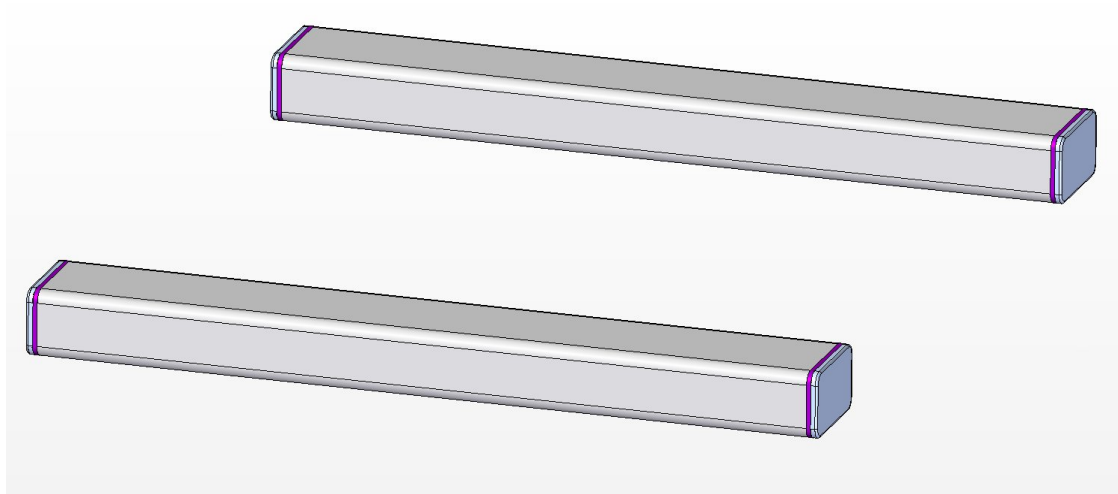

3.

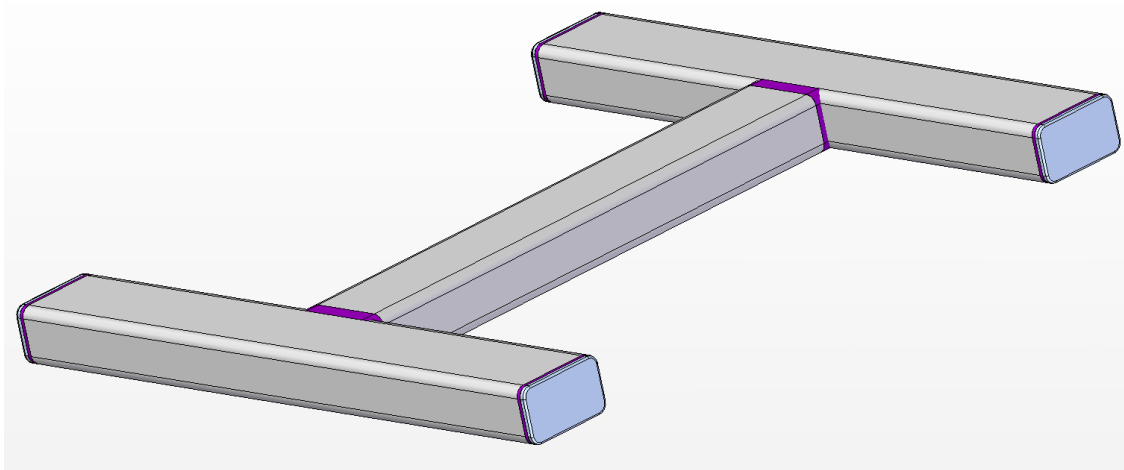
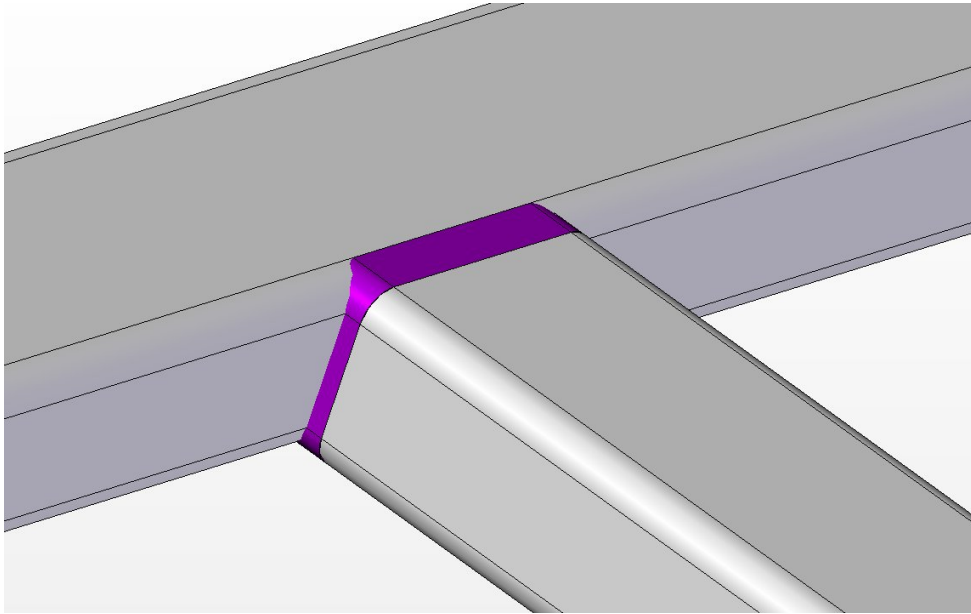

4.

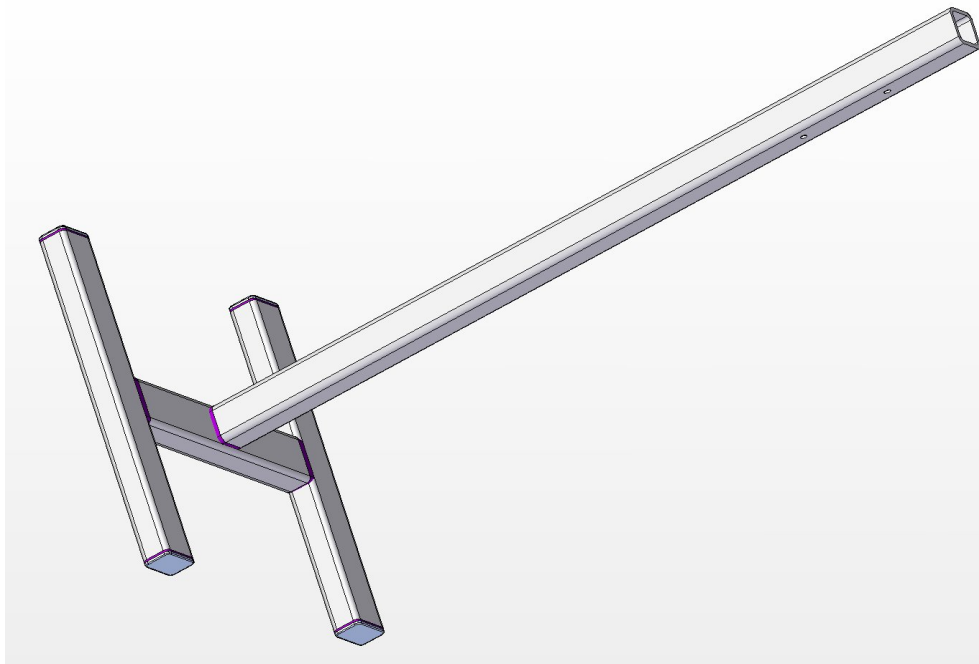
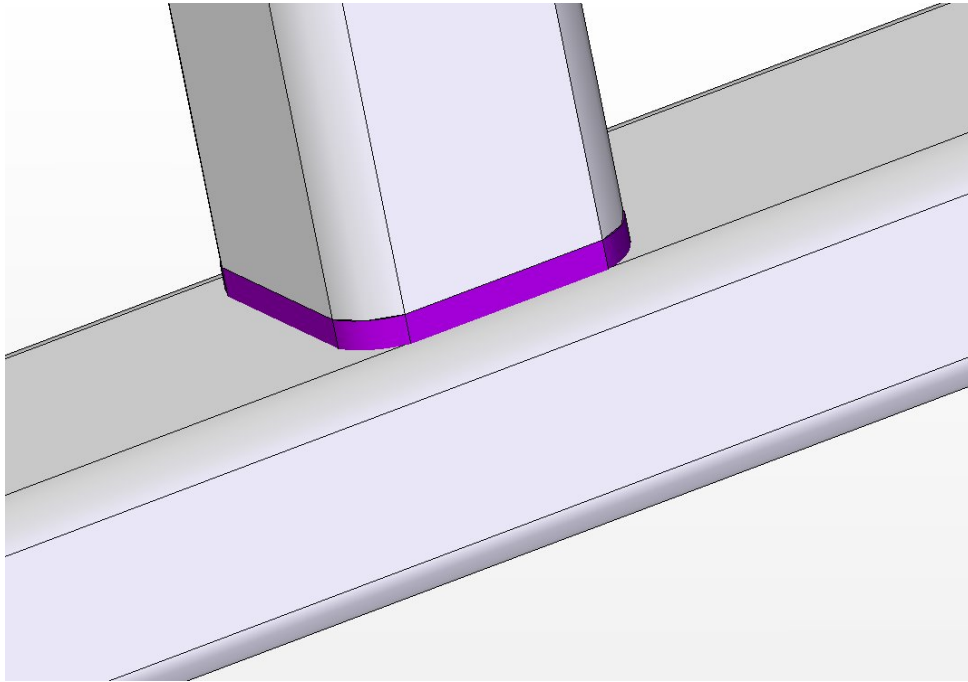

5.

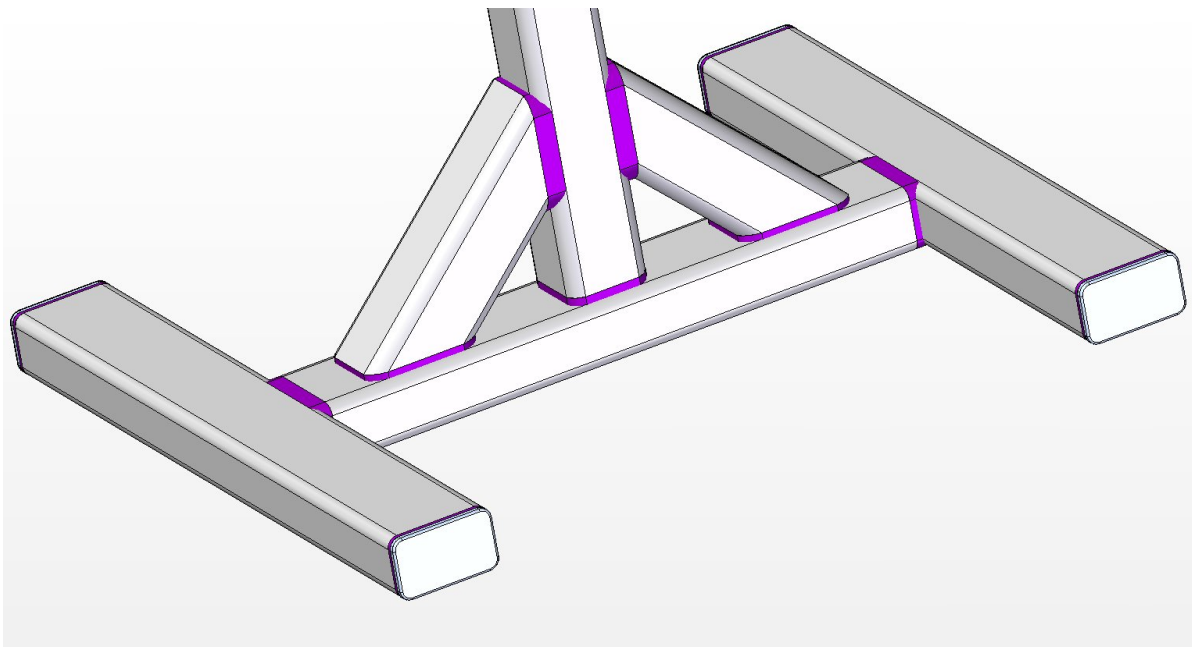
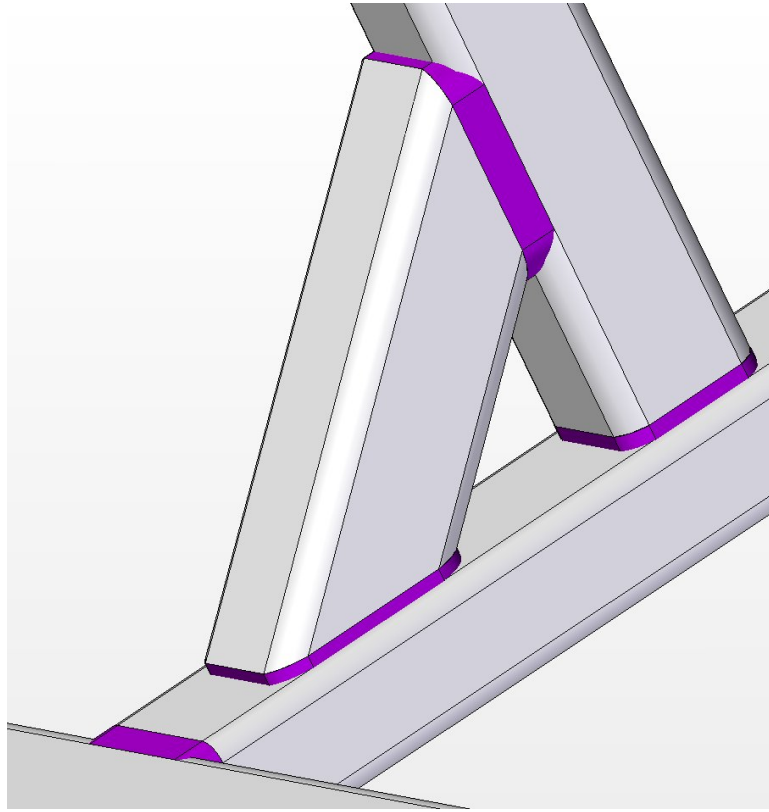

6.

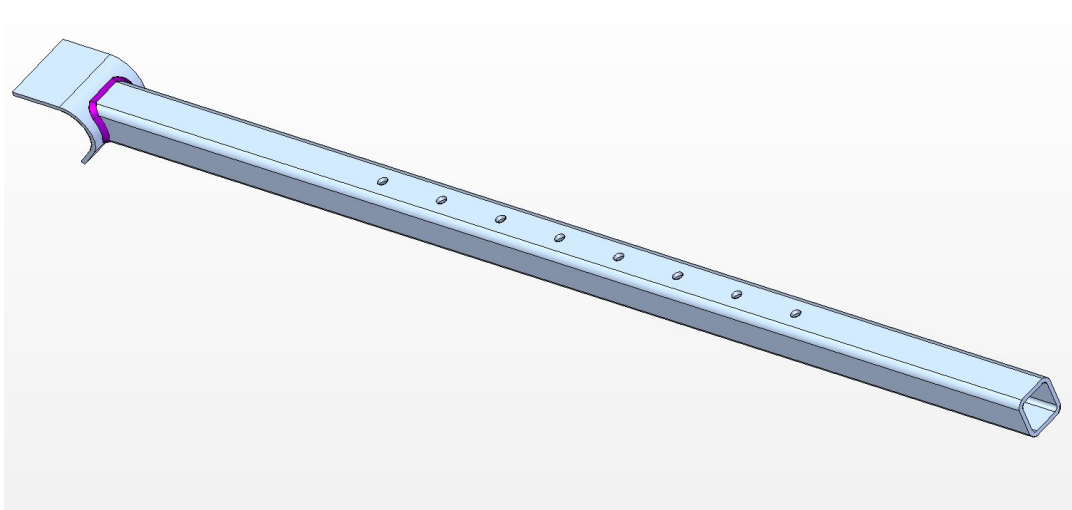
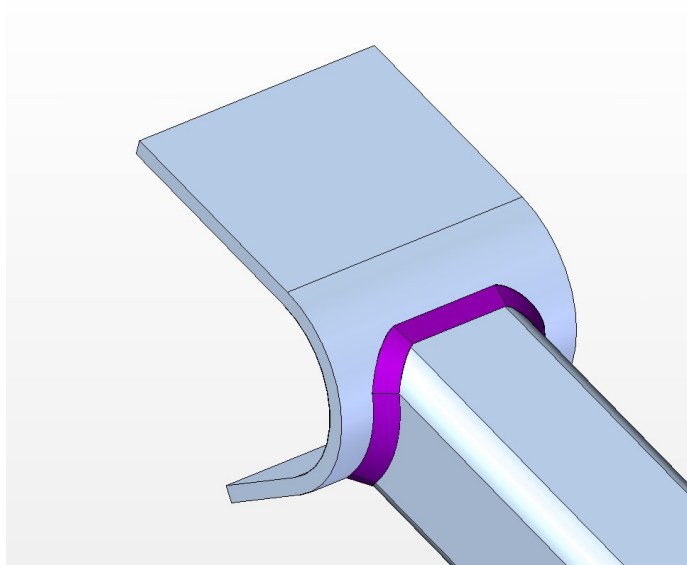

7.

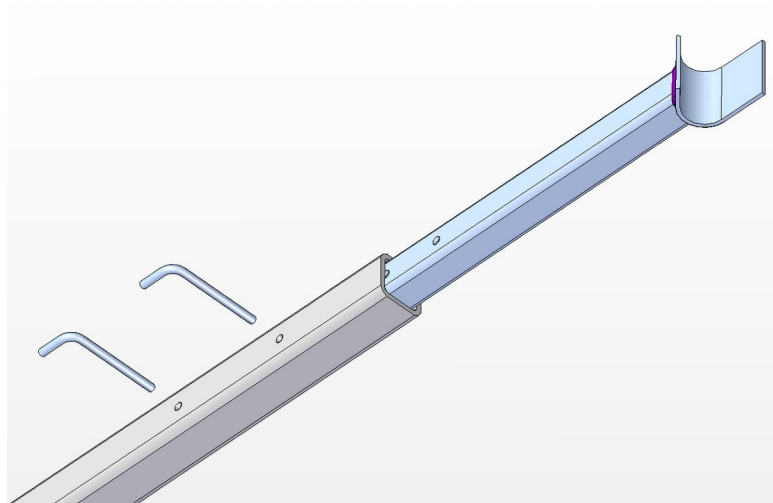

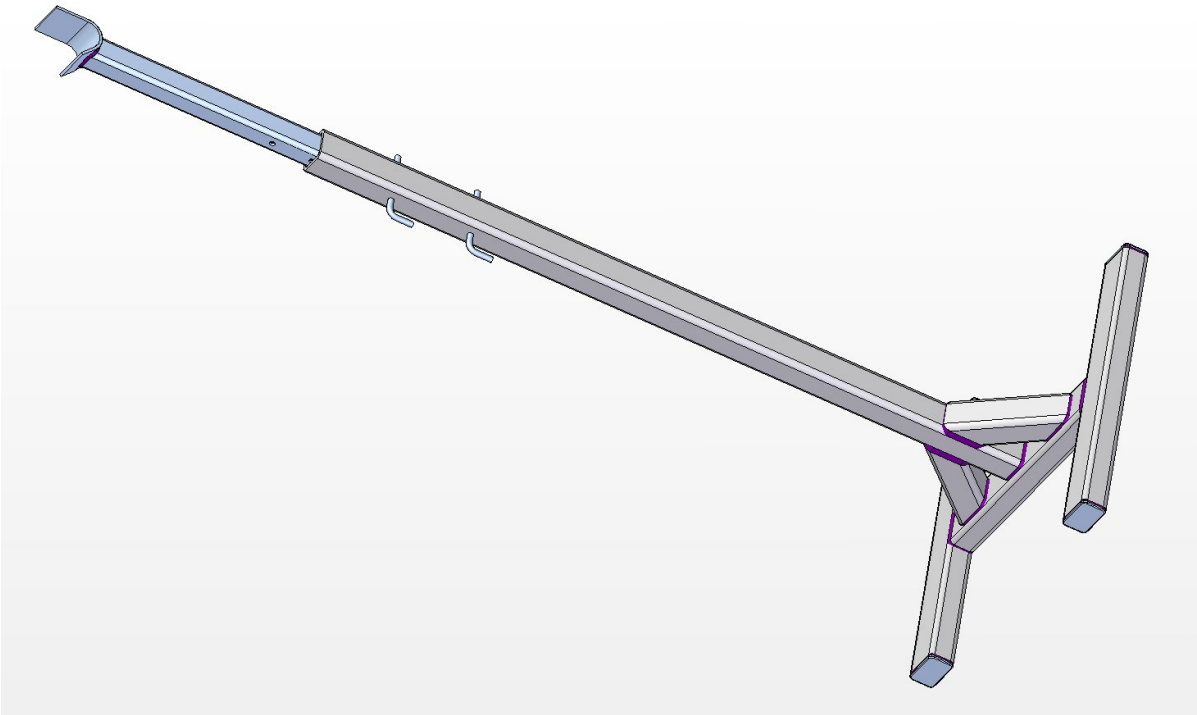
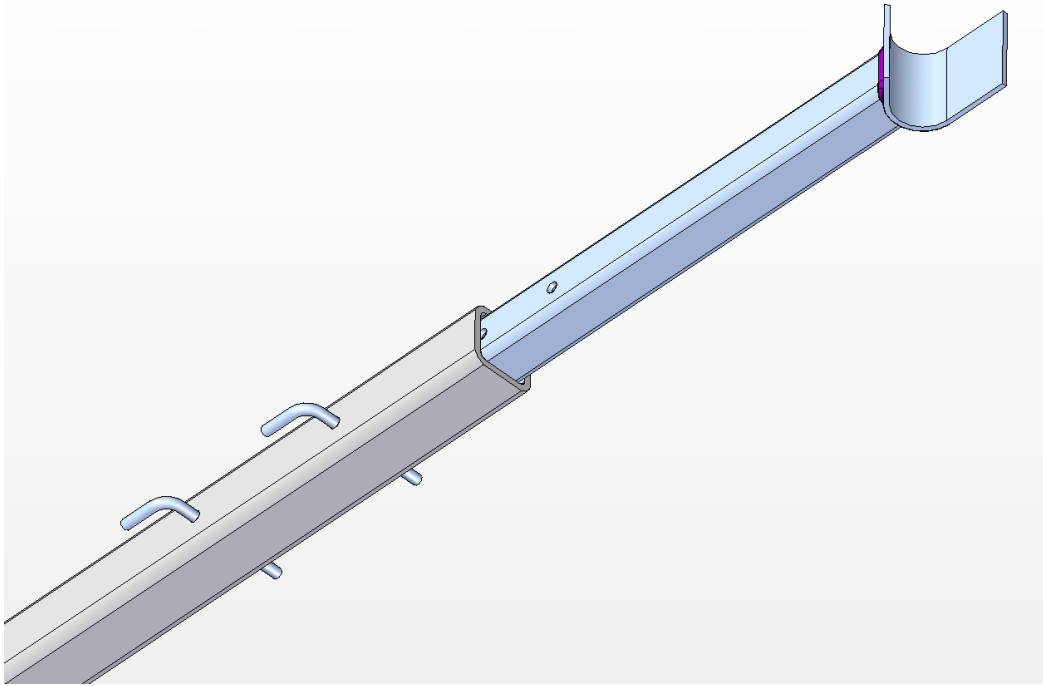

4. Leg developer sub-assembly

1.

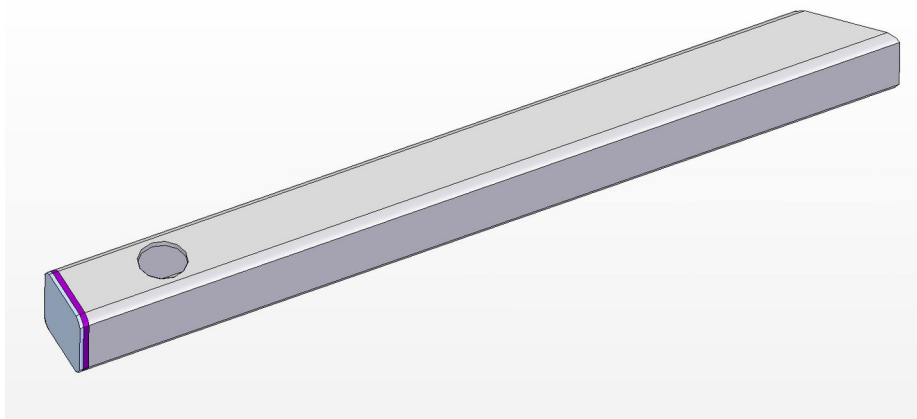
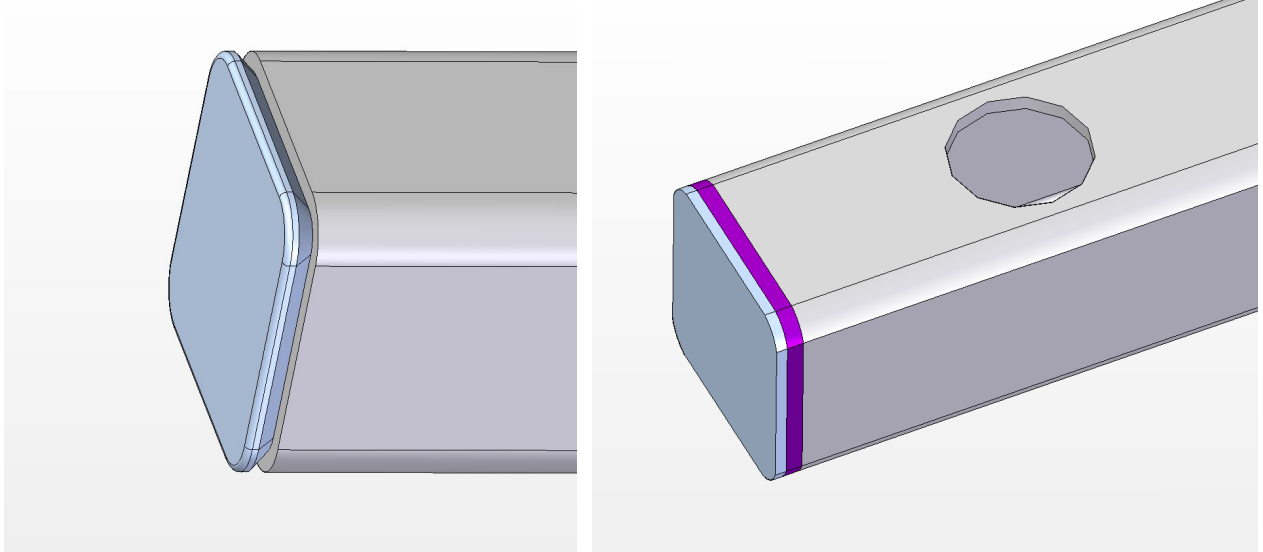

2.

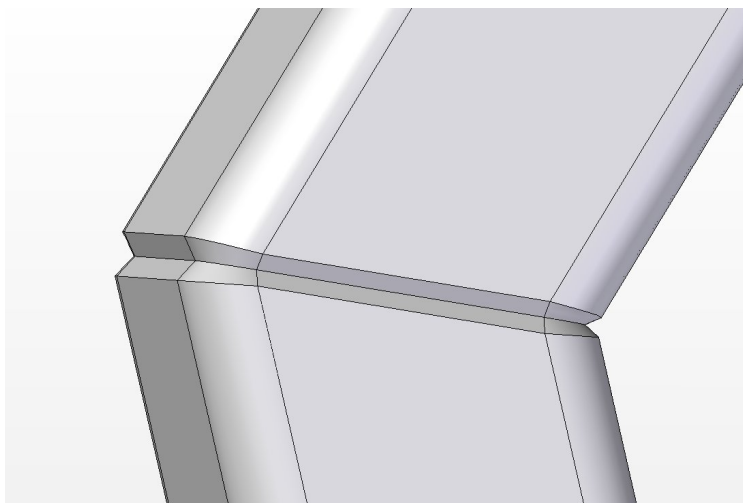

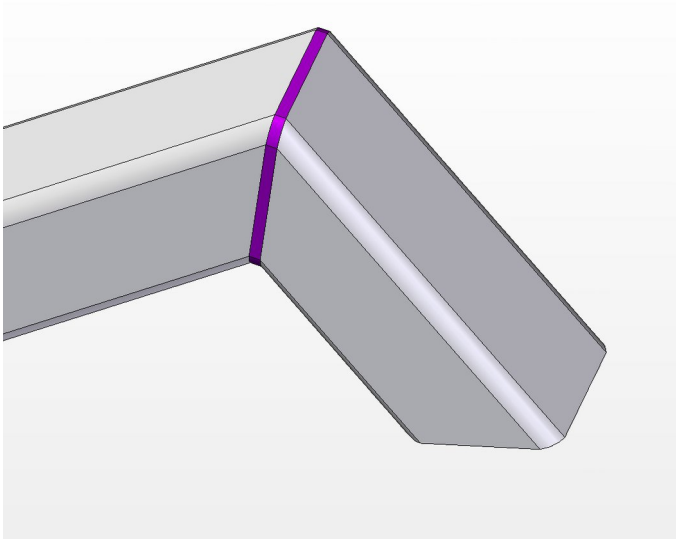

3.

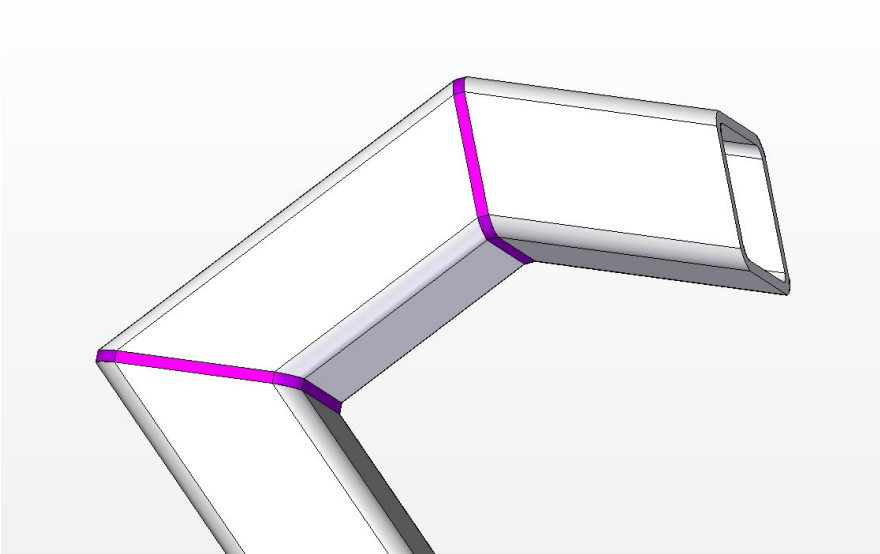
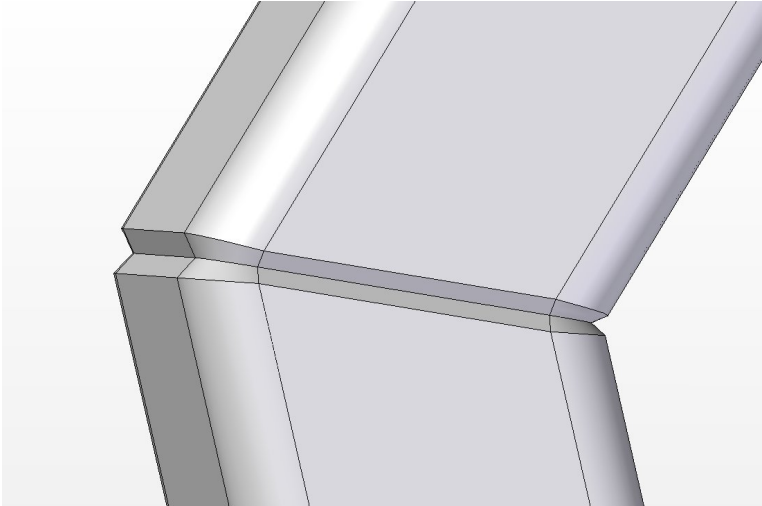

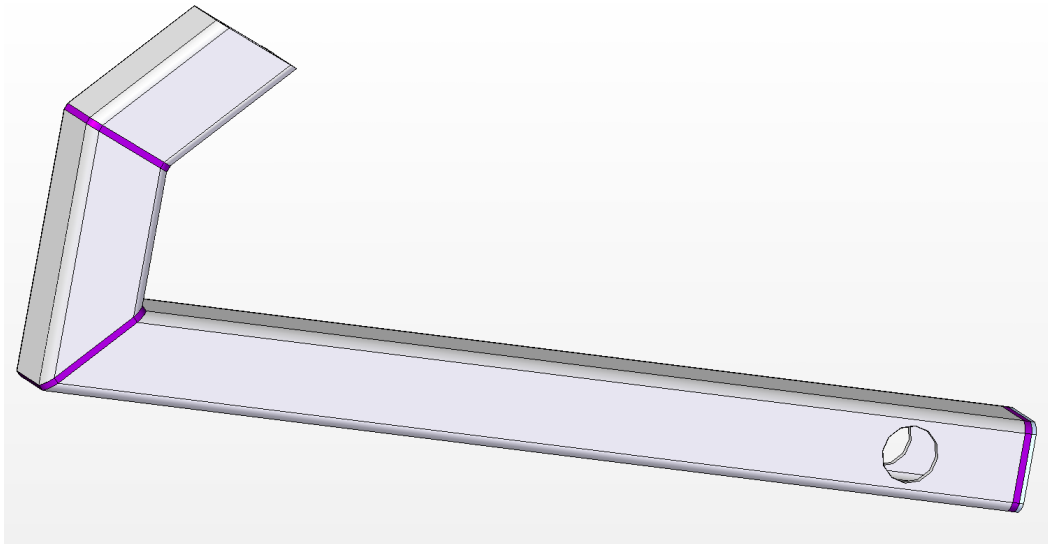

4.

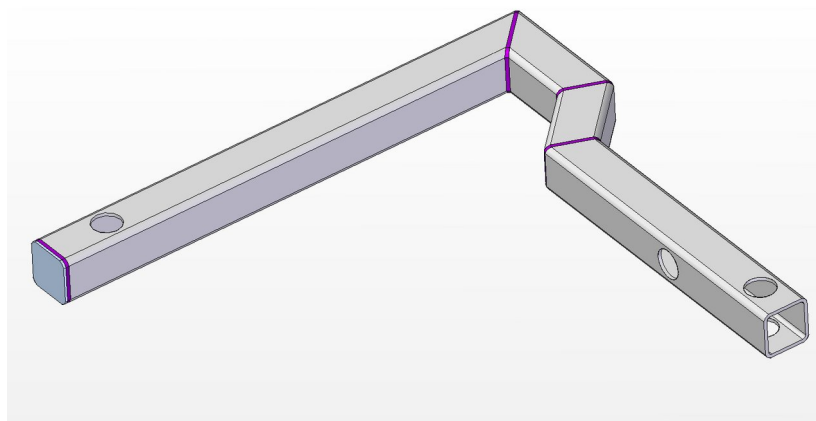
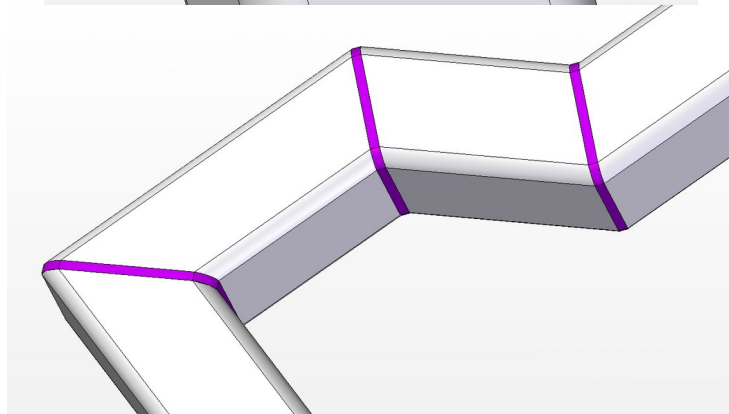
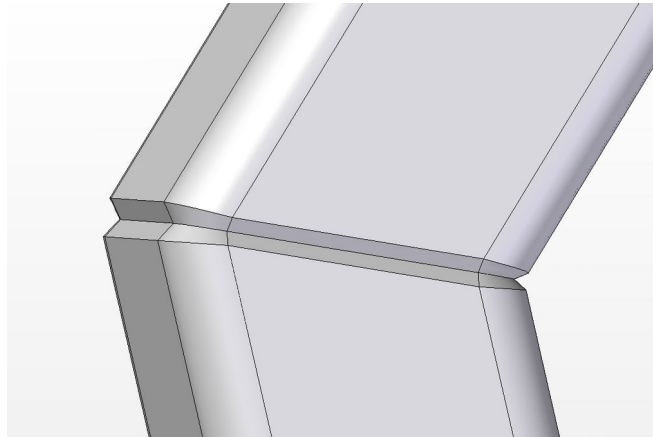

5.

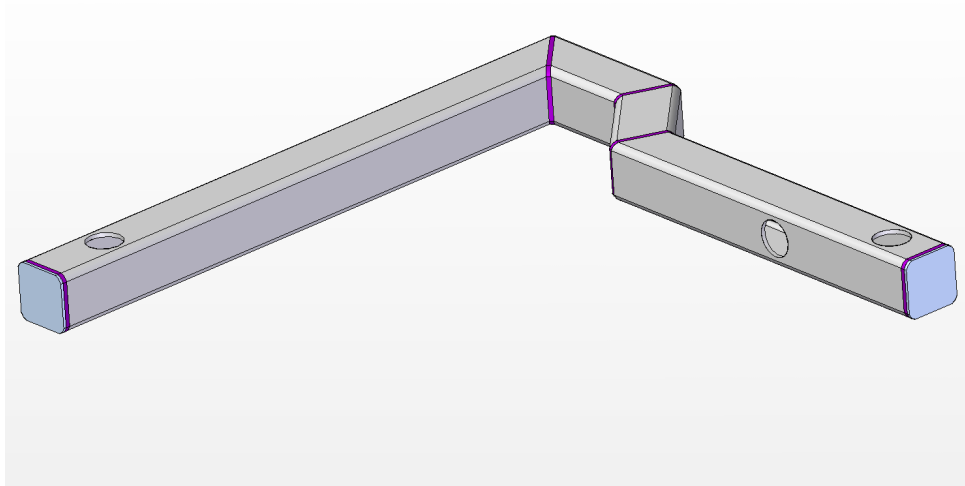
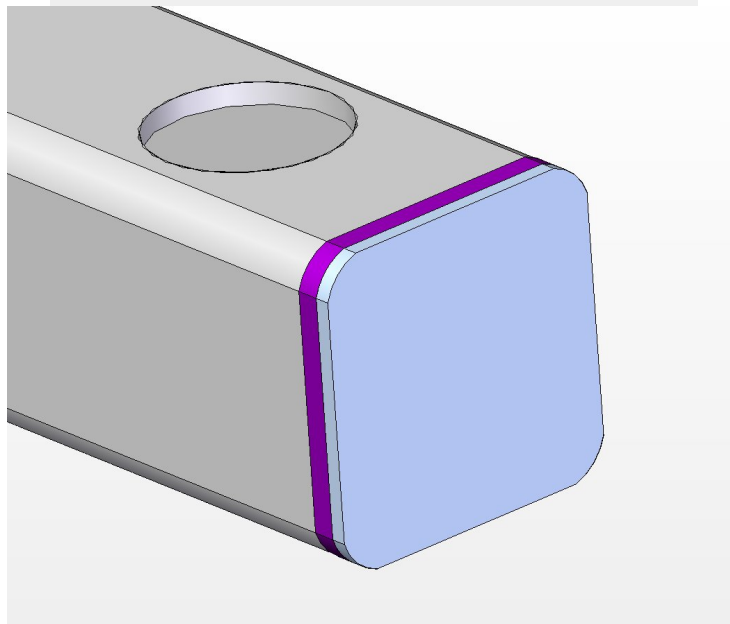
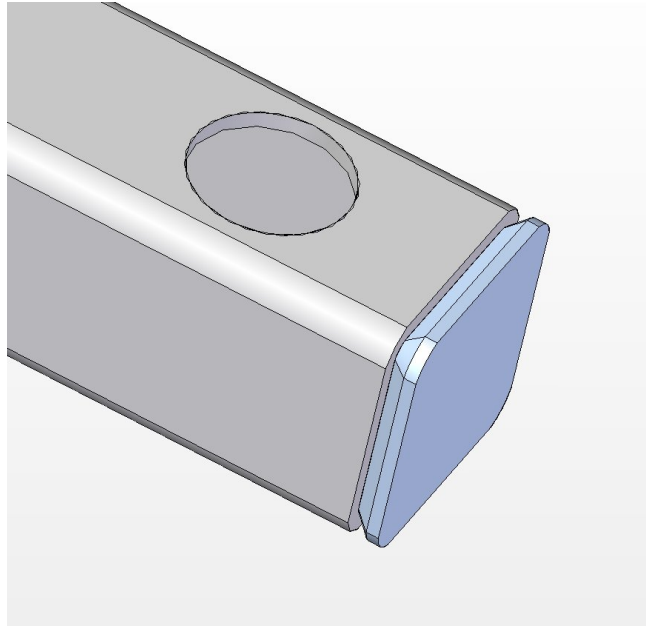

6.

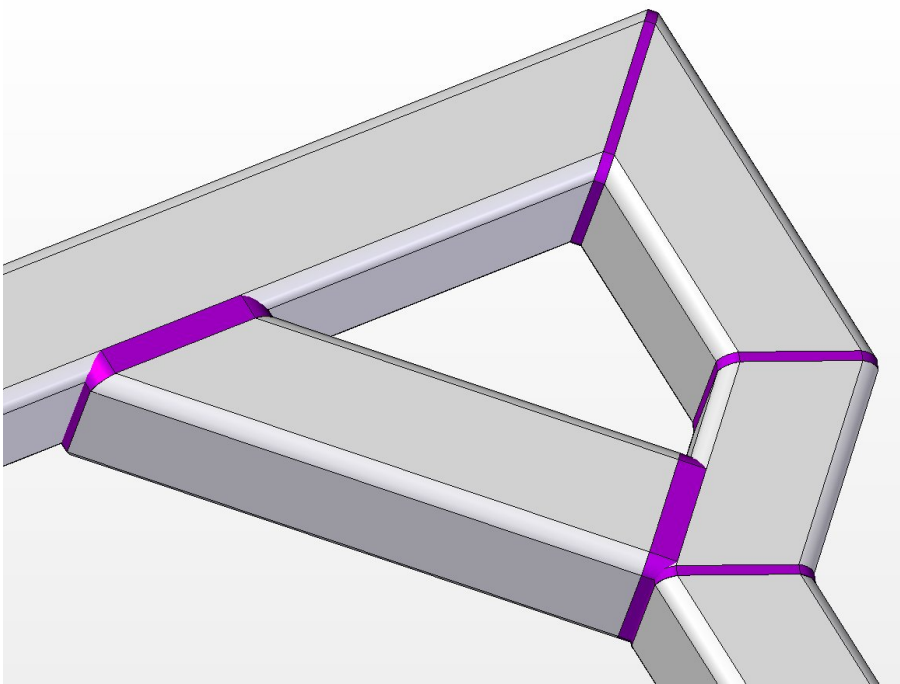

7.

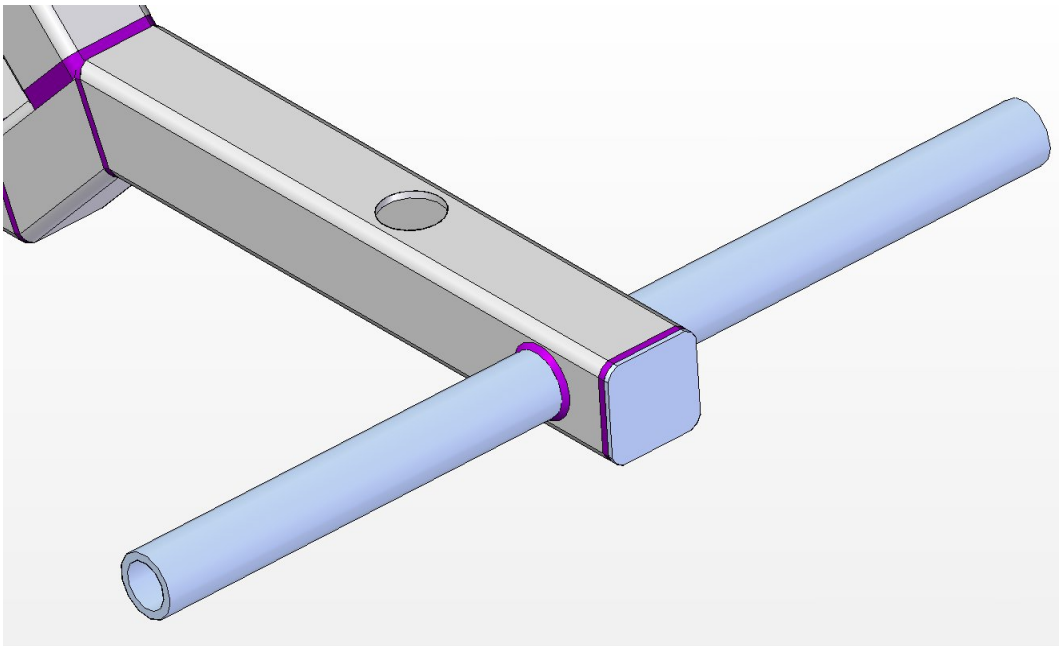

8.

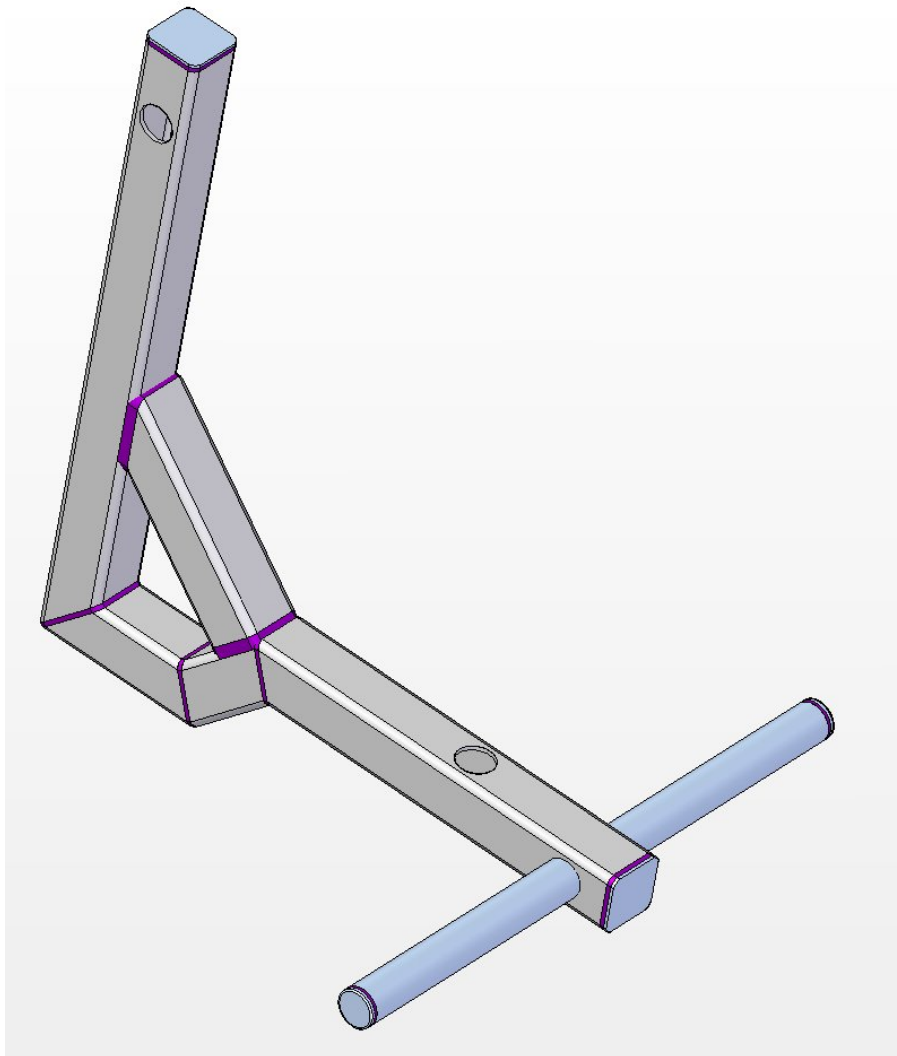
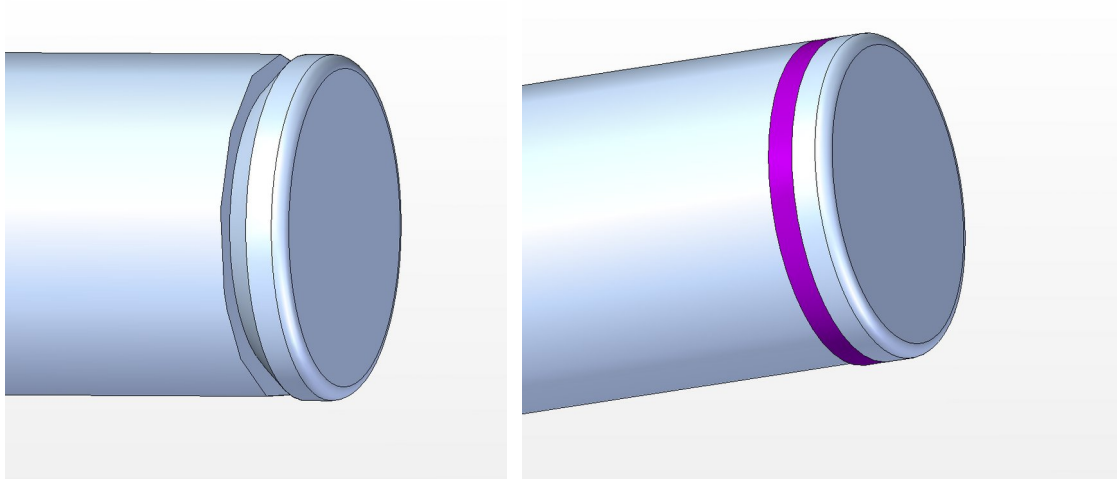

9.

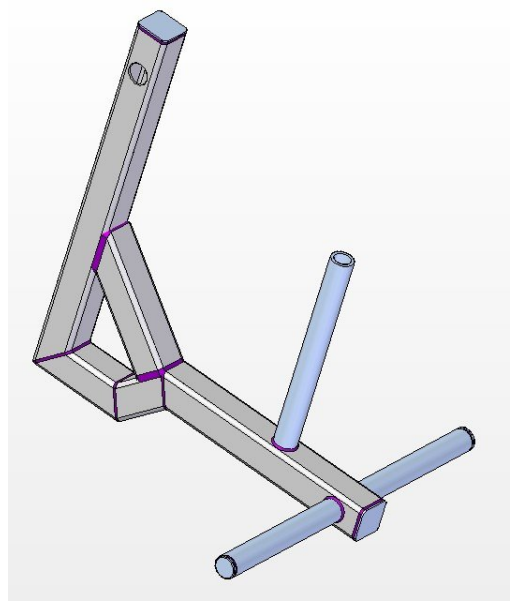
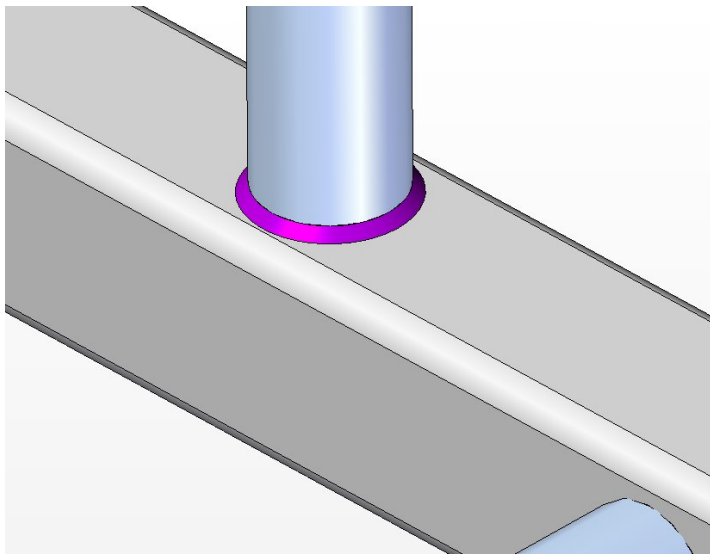

10.

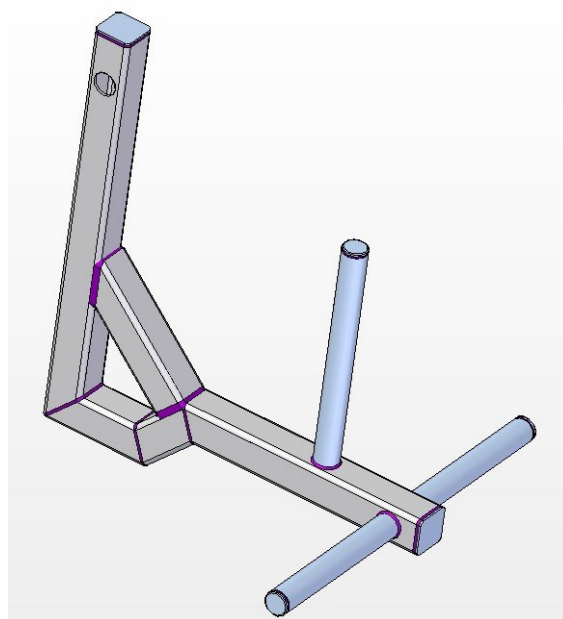
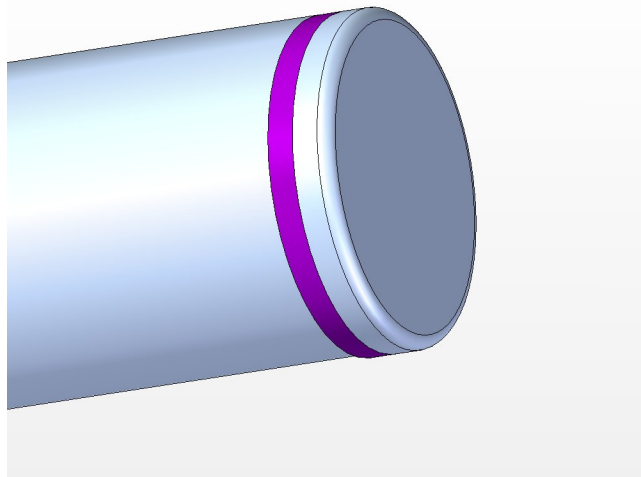
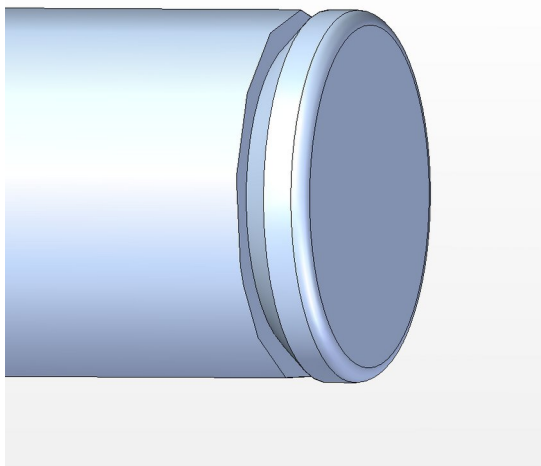

11.

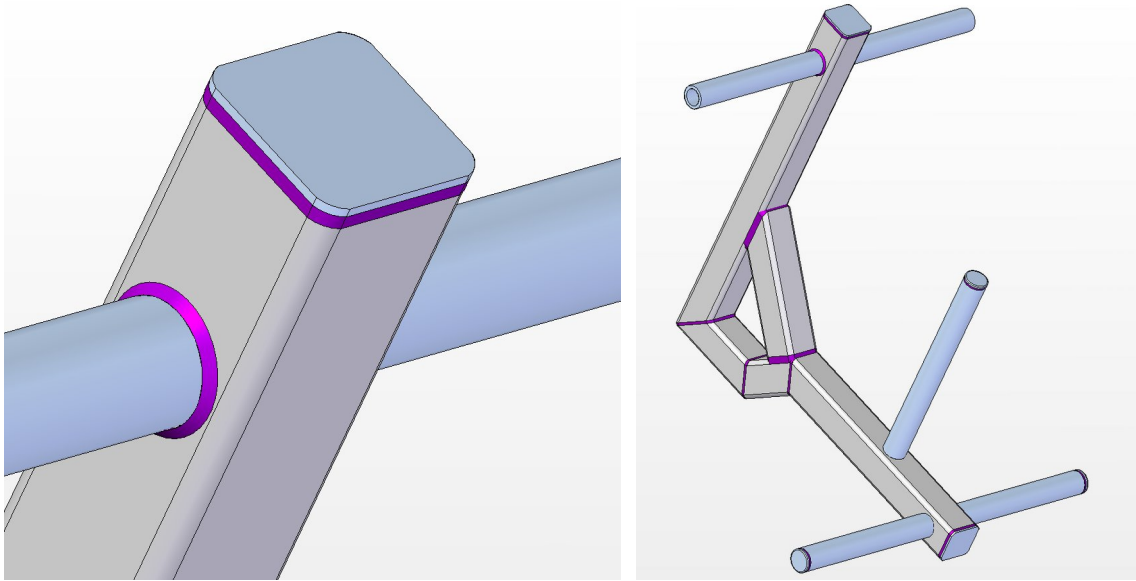

12.

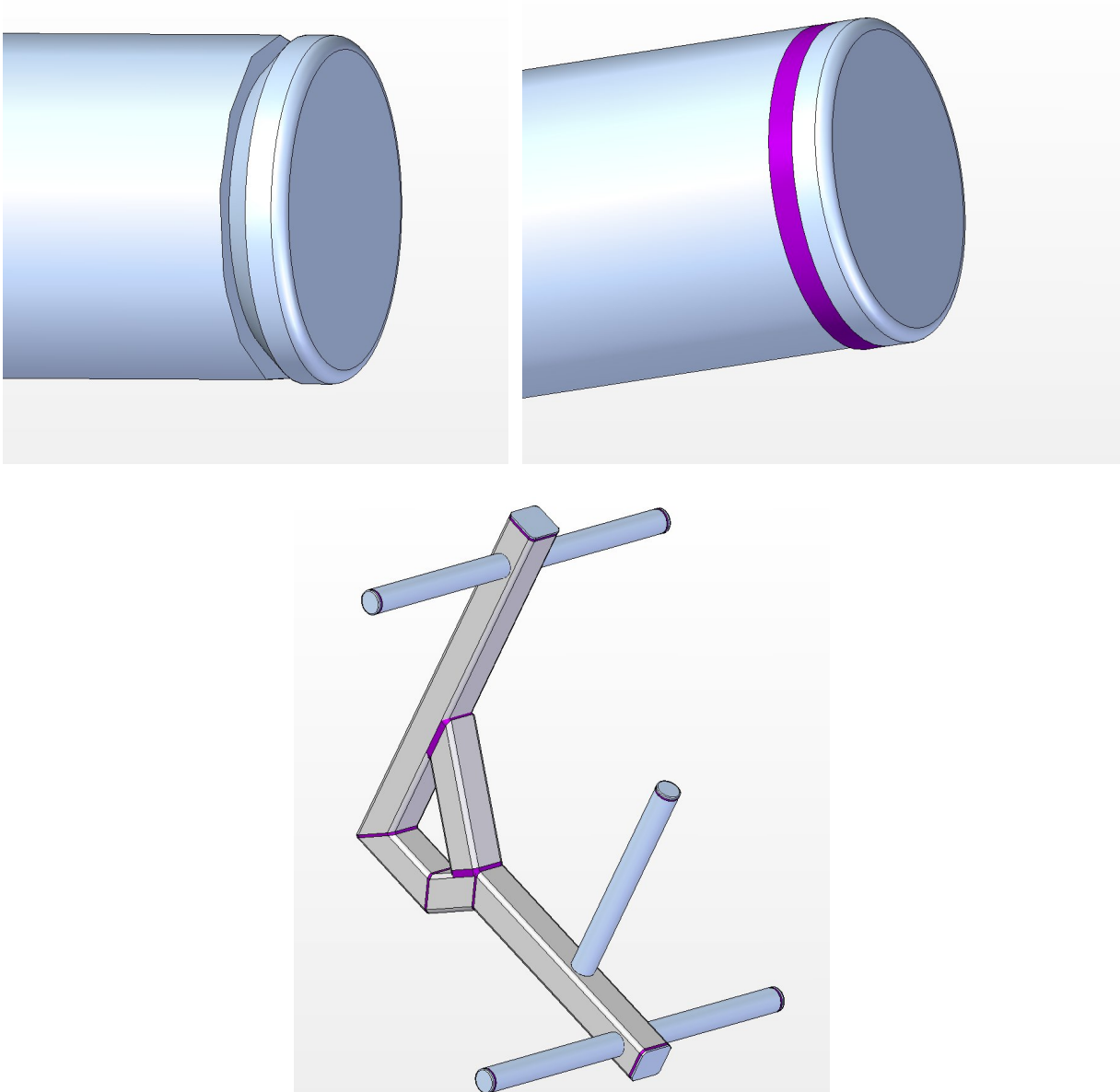

13.

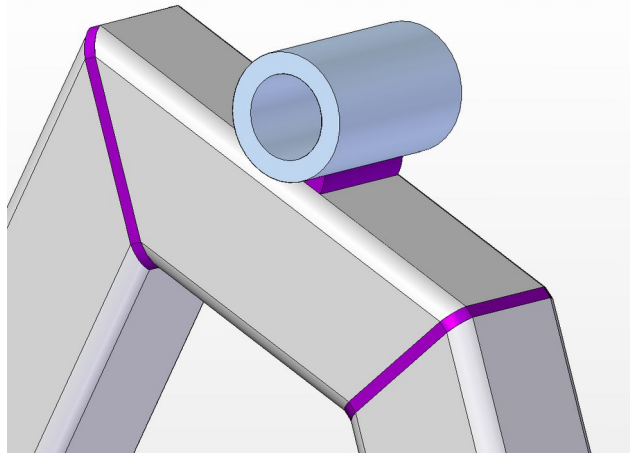

14.

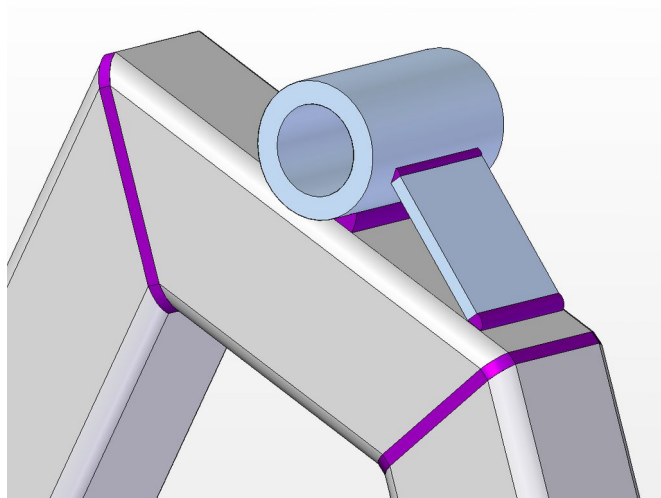

15.

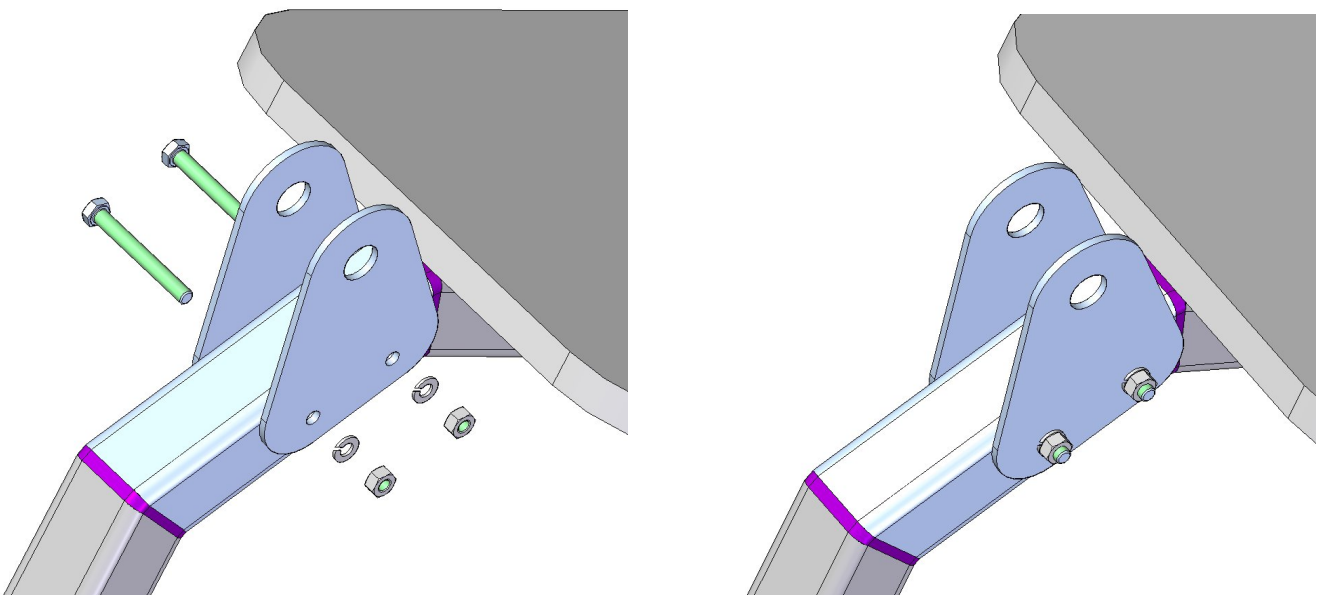

16.

